



**Ritu Raju, PhD**  
President and CEO

February 14, 2024

**Burlington Center**  
496 McCanna Pkwy.  
Burlington, WI 53105-3623

**Elkhorn Campus**  
400 County Road H  
Elkhorn, WI 53121-2046

**HERO (Health And  
Emergency Response  
Occupations) Center**  
380 McCanna Pkwy.  
Burlington, WI 53105-3622

**Horizon Center For  
Transportation  
Technology**  
4940 - 88th Avenue  
Kenosha, WI 53144-7467

**Inspire Center**  
3520 - 30th Avenue  
Kenosha, WI 53144-1690

**Kenosha Campus**  
3520 - 30th Avenue  
Kenosha, WI 53144-1690

**Lakeview Advanced  
Technology Center**  
9449 - 88th Avenue (Highway H)  
Pleasant Prairie, WI 53158-2216

**Racine Campus**  
1001 South Main Street  
Racine, WI 53403-1582

**SC Johnson  
iMET (Integrated  
Manufacturing  
& Engineering  
Technology) Center**  
Renaissance Business Park  
2320 Renaissance Blvd.  
Sturtevant, WI 53177-1763

**WGTD HD**  
Your Gateway to Public Radio  
wgttd.org  
262.564.3800

**gtc.edu**  
**800.247.7122**

## GATEWAY TECHNICAL COLLEGE DISTRICT BOARD

Regular Meeting – Thursday, February 20, 2025 – 8:00 am  
In-Person and Virtual Meeting  
SC Johnson iMET Center, Kopper Auditorium  
2320 Renaissance Blvd, Sturtevant, WI 53177

Join Webinar <https://gtc.zoom.us/j/81435821204>

The Gateway Technical College District Board will hold its regular meeting on Thursday, February 20, 2025, at 8:00 am as an in-person and virtual meeting. The agenda is included. The public may attend in person or access the meeting using the webinar link listed above.

For virtual citizen comments please contact Liz Allen at [allene@gtc.edu](mailto:allene@gtc.edu) prior to the meeting.

Ritu Raju, Ph.D.  
President and Chief Executive Officer

To request disability accommodations, contact the Director of Compliance at [262-564-3062](tel:262-564-3062) / Wisconsin Relay 711, or [compliance@gtc.edu](mailto:compliance@gtc.edu), at least three days in advance.  
To view Gateway's policy on equal opportunity and Notice Under the Americans with Disabilities Act, visit [gtc.edu/eoo](http://gtc.edu/eoo).

**GATEWAY TECHNICAL COLLEGE DISTRICT BOARD**  
 Regular Meeting – Thursday, February 20, 2025 – 8:00 am  
 In-Person and Virtual Meeting  
 SC Johnson iMET Center, Kopper Auditorium  
 2320 Renaissance Blvd, Sturtevant, WI 53177

Join Webinar <https://gtc.zoom.us/j/81435821204>

Info. / Disc	Action	Roll Call	<b>AGENDA</b>	Page
<b>X</b>			<b>Call to Order</b> Open Meeting Compliance	<b>4</b>
		<b>X</b>	<b>Roll Call</b>	<b>4</b>
	<b>X</b>		<b>Approval of Agenda</b>	<b>5</b>
	<b>X</b>		<b>Approval of Minutes</b> A. January 14, 2025 – Regular Meeting	<b>5</b>
<b>X</b>			<b>Citizen Comments</b>	<b>9</b>
<b>X</b>	<b>X</b> <b>X</b>		<b>Chairperson’s Report</b> A. Board Monthly Evaluation Summary B. Review Wording of Policy 3.1 C. Review Wording of Policy 3.3	<b>10</b> <b>11</b> <b>12</b> <b>13</b>
<b>X</b>			<b>Board Member Community Reports</b>	<b>14</b>
<b>X</b> <b>X</b> <b>X</b> <b>X</b>			<b>President’s Report</b> A. Announcements B. Dashboard Report C. Updates on Executive Orders D. Budget Forecast Review - Sharon Johnson	<b>15</b> <b>16</b> <b>17</b> <b>18</b> <b>19</b>
<b>X</b>			<b>Student Trustee Report</b>	<b>20</b>
		<b>X</b>	<b>Operational Agenda</b> A. Action Agenda 1. Resolution No. F-2024-2025E.1 – Resolution Authorizing the Issuance of \$1,000,000 General Obligation Promissory Notes, Series 2024-2025E, of Gateway Technical College District, Wisconsin 2. Resolution No. B-2025 A.1 & A.2 – Approval for the North Building Toilet Room and Office Remodel, Elkhorn Campus	<b>21</b> <b>22</b> <b>26</b>
	<b>X</b>			

Info. / Disc	Action	Roll Call	<b>AGENDA</b>	Page
	<b>X</b>		B. Consent Agenda 1. Bid No. 1732 2. Finance a. Summary of Revenues and Expenditures b. Cash and Investment Schedules 3. Personnel Report 4. Contracts for Instructional Delivery a. Business and Workforce Solutions b. Protective Services c. High School 5. Advisory Committee Activity Report	<b>38</b> 39 44 52 56 58 62 65 75
	<b>X</b>		<b>Policy Governance Monitoring Reports</b> A. Ends Policy Monitoring 1) <u>College Ends Policy</u> - The tri-county community benefits from affordable higher education that allows residents to develop knowledge and skills for family-supporting careers that contribute to the growth and sustainability of the local economy at a cost commensurate with the value of services provided. <b>#1 Students demonstrate the knowledge and skills and self-confidence required for employability, career advancement, a global perspective, and lifelong learning.</b> – Oliver Debe and Dr. Kelly Demerath	<b>77</b> 78
	<b>X</b>		B. Executive Limitations 1) 3.7 Communication and Counsel to the Board – Jacqueline Morris and Lee Colony	79
<b>X</b>		<b>X</b>	<b>Next Meeting Date and Adjourn</b> A. Regular Meeting – Thursday, March 20, 2025, <b>3:00 pm</b> , Virtual and In-Person, Horizon Center, Kenosha, WI B. Adjourn – Immediately following the Regular Meeting, the Gateway Technical College District Board will meet for a <b>semi-annual retreat</b> , which <b>does not have a public virtual or in-person option</b> . No action will be taken.	<b>80</b>

**GATEWAY TECHNICAL COLLEGE DISTRICT BOARD**  
Regular Meeting – Thursday, February 20, 2025 – 8:00 am  
In-Person and Virtual Meeting  
SC Johnson iMET Center, Kopper Auditorium  
2320 Renaissance Blvd, Sturtevant, WI 53177

Join Webinar <https://gtc.zoom.us/j/81435821204>

CALL TO ORDER  
Open Meeting Compliance

ROLL CALL

Ram Bhatia	_____
Benjamin DeSmidt	_____
William Duncan	_____
Preston Gardner	_____
Zaida Lange-Irisson	_____
Rebecca Matoska-Mentink	_____
Andrea Nunez	_____
Nicole Oberlin	_____
Scott Pierce	_____
Jason Tadlock	_____

**Our Positive Core – Gateway Technical College District Board**

Our shared strengths as a Board that we draw upon to do our work:

- Belief in the value of Gateway Technical College
- Commitment to our community
- Common sense of mission
- Mutual respect
- Sense of humor
- Open-mindedness & willingness to question

## APPROVAL OF AGENDA

Items on the Consent Agenda for discussion

## APPROVAL OF MINUTES

A. January 14, 2025 – Regular Meeting

GATEWAY TECHNICAL COLLEGE DISTRICT BOARD  
Regular Meeting, January 14, 2025

The Gateway Technical College District Board met virtually and in person on the Kenosha Campus on Tuesday, January 14, 2025. The meeting was called to order at 8:04 am by Jason Tadlock, Chairperson.

**Open Meeting Compliance:** L. Allen confirmed the meeting was duly noticed in accordance with state statutes for open meeting compliance.

**Roll Call**

**Present:** Ram Bhatia, Preston Gardner, Zaida Lange-Irison, Rebecca Matoska-Mentink, Andrea Nunez (student trustee), Nicole Oberlin, Scott Pierce and Jason Tadlock

**Virtual:** William Duncan

**Excused:** Benjamin DeSmidt

Also in attendance were President Ritu Raju, Recorder Liz Allen, Administrative Assistant David Elliott and 50 virtual and 13 in person citizens/reporters.

**Approval of Agenda:** It was moved by S. Pierce, seconded by R. Matoska-Mentink and carried to approve the Agenda.

**Approval of Minutes:** It was moved by Z. Lange-Irison, seconded by R. Matoska-Mentink and carried to approve the Minutes of the December 19, 2024 Regular Meeting.

**Citizen Comments:** There were no citizen comments.

**Chairperson's Report - Board Evaluation Summary:**

5 of 9 Trustees Responded to the January survey plus the Student Trustee. Below are the comments received.

Strategic: The agenda items were well planned.

Task: I appreciated the complete results of the Engage survey.

Action: Good presentation on Engage survey results, action item and policy governance monitoring report. During the review of Governance Policy 1.5 I would like to commend our chairman for keeping to discussion related to our review of the policy as was outlined by the agenda.

Results: Presentations on Engage survey, use of general obligation promissory notes funds, and the ends policy monitoring are evidence of enacting governing policies and assuring successful college performance. Well organized.

**Chairperson's Report – Wording Review of Governance Policy 1.5:** The Trustees reviewed the wording of the policy. It was moved by R. Bhatia, seconded by R. Matoska-Mentink and carried to approve the wording of Policy 1.5. S. Pierce cast a 'no' vote.

**Chairperson's Report – Wording Review of Governance Policy 1.6:** The Trustees reviewed the wording of the policy. It was moved by R. Bhatia, seconded by P. Gardner and carried to approve the wording of Policy 1.6.

**Chairperson's Report – Wording Review of Governance Policy 1.7:** The Trustees reviewed the wording of the policy. It was moved by R. Bhatia, seconded by R. Matoska-Mentink and carried to approve the wording of Policy 1.7.

**Board Member Community Reports:** Z. Lange-Irison thanked Stephanie Sklba for her 25 years of service at Gateway.S. Sklba is retiring with her last day being 1/31/25. W. Duncan stated the MOU with Fox Valley Technical College will expire 6/30/25 and that TEAM Inc. will then handle the accounting portion. W. Duncan also stated he does not plan to run for a DBA board seat this April. R. Bhatia thanked W. Duncan for his years of service on the DBA board. He also stated that Gateway has been represented in past years by the current chair. S. Pierce stated Gateway is experiencing a tragic loss due to two ELC members leaving, Stacy Rily and Stephanie Sklba and has concerns about leadership. Dr. Raju stated she doesn't see S. Sklba leaving as a loss. She is retiring after 25 years and that it is the

natural ebb and flow of an organization and is comfortable with it. Dr. Raju thanked Stephanie for her years of service and wished her well in her retirement.

**President's Report – Announcements:** President Raju provided college updates.

**President's Report – Dashboard:** The dashboard report included information about the recent Nursing Pinning Ceremony, the Law enforcement Academy and Energage results.

**President's Report – Energage Results from Fall 2024 Survey.** Magan Perez and Michelle Borckardt presented on this topic.

**Student Trustee Report:** Andrea Nunez gave an update on student activities that have been taking place over the past month.

**Operational Agenda - Action Agenda – Resolution No. F-2024-2025D.2 – DRAFT Resolution Awarding the Sale of \$1,500,000 General Obligation Promissory Notes, Series 2024-2025D, of Gateway Technical College District, Wisconsin**

Administration is recommending approval of a resolution awarding the sale of General Obligation Promissory Notes, Series F-2024- 2025D; in the principal amount of \$1,500,000 for the public purpose of financing building remodeling and improvement projects.

**Following discussion, it was moved by S. Pierce, seconded by R. Matoska-Mentink and carried to roll call vote for approval of Resolution No. F-2024-2025D.2 – DRAFT Resolution Awarding the Sale of \$1,500,000 General Obligation Promissory Notes, Series 2024-2025D.**

**Aye: 8**

**No: 0**

**Abstaining: 0**

**Excused:1**

**Consent Agenda**

**It was moved by R. Bhatia, seconded by Z. Lange-Irison and carried that the following items in the consent agenda be approved.**

**BID 1721 – Barber-Cosmetology Remodel, Burlington Campus; project cost \$948,000.00**

**Finance - Summary of Revenue and Expenditures:** Approved the summary of revenue and expenditures as of 12/31/24.

**Finance - Cash and Investment Schedules:** Approved the monthly cash reconciliation, investment schedule and investment report.

**Personnel Report for December:** Approved the personnel report of (2) retirements and (4) separations.

**BWS Contracts for Instructional Delivery:** Approved the contracts for instructional delivery report for December 2024.

**Protective Services Contracts for Instructional Delivery:** Approved the contracts for instructional delivery report for December 2024.

**High School Contracts for Instructional Delivery:** Approved the contracts for instructional delivery report for January 2025.

**Advisory Committee Activity Report:** Approved new members as of January 1, 2025.

**Executive Limitations - 3.1 General Executive Limitations:** Jacqueline Morris led the presentation.

Following discussion, it was moved by R. Bhatia, seconded by P. Gardner and carried to approve that this report is evidence that the college is making progress on Executive Limitations 3.1.

**Policy Governance Monitoring Report – Ends Statement #5:** John Zehren and Steve Whitmoyer led the presentation.

Following discussion, it was moved by R. Bhatia, seconded by Z. Lange-Irison and carried to approve that this report is evidence that the college is making progress on Ends Statement #5.

**Next Meeting Date and Adjourn**

Regular Meeting - Thursday, February 20, 2025, 8:00 am, Virtual and In-Person, SC Johnson iMET Center, Sturtevant, WI.

At approximately 9:32 am, it was moved by R. Matoska-Mentink, seconded by W. Duncan and carried by a roll call vote that the meeting was adjourned and the Gateway Technical College District Board moved to Executive Session pursuant to Wisconsin Statutes 19.85(1)© to discuss the **President's Mid-Year Review and Personnel Issues**. The Board reserves the right to reconvene in open session to take action on items discussed in closed session.

**Aye: 8**

**No: 0**

**Abstaining: 0**

**Excused: 1**

At approximately 11:31 am it was moved by S. Pierce, seconded by R. Matoska-Mentink that the meeting adjourn. The board did not reconvene in open session.

Submitted by,

Nicole Oberlin, Secretary  
Gateway Technical College Board of Trustees



## CITIZEN COMMENTS

The Gateway Technical College District Board has established a limit of thirty minutes for citizen comments. Individuals will be limited to three to five minutes for their comments depending on the number of individuals who wish to address the Board. Citizens wishing to address the Board are to sign up prior to the meeting on the forms provided at the entrance to the meeting room.

## CHAIRPERSON'S REPORT

- A. Board Monthly Evaluation Summary
- B. Review Wording of Policy 3.1
- C. Review Wording of Policy 3.3

# GATEWAY TECHNICAL COLLEGE DISTRICT BOARD

Roll Call	_____
Action	_____
Information	_____X_____
Discussion	_____

## CHAIRPERSON'S REPORT Board Evaluation Summary

Governance Process:  
Liaison:

Policy 1.2 – Governing Philosophy Board  
Jason Tadlock

# GATEWAY TECHNICAL COLLEGE DISTRICT BOARD

Roll Call	_____
Action	<u>  X  </u>
Information	_____
Discussion	_____

## **POLICY GOVERNANCE REVIEW** **Review the wording of Governance Policy 3.1**

### SECTION 3 – EXECUTIVE LIMITATIONS 3.1 GENERAL EXECUTIVE LIMITATION

The President shall not cause or allow any practice, activity, decision, or organizational circumstance that is either unlawful, unethical, or imprudent.

Without limiting the scope of the foregoing statement, the President shall not cause or allow any practice, activity, decision, or organizational circumstance which:

1. Deviates materially from the Board's Ends policy.
2. Fails to serve the common and unique interests of the three counties within the Gateway district.
3. Jeopardizes Gateway's continued accreditation relationship with the Higher Learning Commission.
4. Is contrary to Gateway's commitments to social responsibility and environmental sustainability.
5. Impedes continuous improvement of college operations.
6. Publicly positions the college in support of or opposition to any political party or candidate for public office.
7. Compromises the safety and security of the college.

### **Question for the Board:**

**Does this policy as written represent an accurate and complete statement of the Board's thinking at this time?**

Governance Process: Policy 1.4 – Board Policy Creation and Review Board  
Liaison: Jason Tadlock

# GATEWAY TECHNICAL COLLEGE DISTRICT BOARD

Roll Call	_____
Action	<u>  X  </u>
Information	_____
Discussion	_____

## **POLICY GOVERNANCE REVIEW** **Review the wording of Governance Policy 3.3**

### SECTION 3 – EXECUTIVE LIMITATIONS 3.3 EMPLOYMENT, COMPENSATION, AND BENEFITS

The President shall not cause or allow jeopardy to the college’s fiscal integrity or public image in regard to employment, compensation, and benefits for employees, consultants, and contract workers.

Without limiting the scope of the foregoing statement, the President shall not:

1. Fail to comply with administrative codes, rules, or regulations set forth by agencies with recognized authority over specific college activities, including administrative policies and rules of Gateway Technical College.
2. Permit conflicts of interest in hiring of employees, consultants, and contract workers.
3. Change his or her own compensation and benefits.
4. Provide for or change the compensation and benefits of other employees except in accordance with college salary schedules and established compensation practices.
5. Promise or imply permanent or guaranteed employment.

### **Question for the Board:**

Does this policy as written represent an accurate and complete statement of the Board’s thinking at this time?

Governance Process: Policy 1.4 – Board Policy Creation and Review Board  
Liaison: Jason Tadlock

## BOARD MEMBER COMMUNITY REPORTS

## PRESIDENT'S REPORT

- A. Announcements
- B. Dashboard Report
- C. Update on Executive Orders
- D. Budget Forecast Review - Sharon Johnson

# GATEWAY TECHNICAL COLLEGE DISTRICT BOARD

Roll Call \_\_\_\_\_  
Action \_\_\_\_\_  
Information   X    
Discussion \_\_\_\_\_

## PRESIDENT'S REPORT Announcements

Policy/Ends Statement:    Policy 2.1



# GATEWAY TECHNICAL COLLEGE DISTRICT BOARD

Roll Call \_\_\_\_\_  
Action \_\_\_\_\_  
Information   X    
Discussion \_\_\_\_\_

## PRESIDENT'S REPORT Dashboard Report

Policy/Ends Statement:

Policy 2.1

# GATEWAY TECHNICAL COLLEGE DISTRICT BOARD

Roll Call \_\_\_\_\_  
Action \_\_\_\_\_  
Information   X    
Discussion \_\_\_\_\_

## PRESIDENT'S REPORT

Update on Executive Orders

Policy/Ends Statement:     Policy 2.1

# GATEWAY TECHNICAL COLLEGE DISTRICT BOARD

Roll Call \_\_\_\_\_  
Action \_\_\_\_\_  
Information   X    
Discussion \_\_\_\_\_

## PRESIDENT'S REPORT

Budget Forecast Review - Sharon Johnson

Policy/Ends Statement:     Policy 2.1

STUDENT TRUSTEE REPORT

## OPERATIONAL AGENDA

### A. Action Agenda

- 1) Resolution No. F-2024-2025E.1 – Resolution Authorizing the Issuance of \$1,000,000 General Obligation Promissory Notes, Series 2024-2025E, of Gateway Technical College District, Wisconsin
- 2) Resolution No. B-2025 A.1 & A.2 – Approval for the North Building Toilet Room and Office Remodel, Elkhorn Campus

**GATEWAY TECHNICAL COLLEGE DISTRICT BOARD**

Roll Call   X    
Action         
Information         
Discussion       

**RESOLUTION NO. F-2024-2025E.1  
RESOLUTION AUTHORIZING THE ISSUANCE OF \$1,000,000  
GENERAL OBLIGATION PROMISSORY NOTES, SERIES 2024-2025E,  
OF GATEWAY TECHNICAL COLLEGE, WISCONSIN**

Summary of Item:           The administration is recommending approval to issue General Obligation Promissory Notes, Series 2024-2025E; in the principal amount of \$1,000,000 for the public purpose of financing building remodeling and improvement projects. This portion of the borrowing is included in the 2024-2025 Budget. Upon approval, appropriate legal notices will be published in the Official District Newspapers.

Attachments:               Resolution No. F-2024-2025E.1

Ends Statements and/or  
Executive Limitations:   Section 4 - Executive Limitations  
                                  Policy 3.5 – Financial Condition

Staff Liaison:            Sharon Johnson

**ROLL CALL**

Ram Bhatia                \_\_\_\_\_

Benjamin DeSmidt        \_\_\_\_\_

William Duncan           \_\_\_\_\_

Preston Gardner         \_\_\_\_\_

Zaida Lange-Irisson      \_\_\_\_\_

Rebecca Matoska-Mentink \_\_\_\_\_

Nicole Oberlin            \_\_\_\_\_

Scott Pierce              \_\_\_\_\_

Jason Tadlock             \_\_\_\_\_

Resolution No. F-2024-2025E.1

RESOLUTION AUTHORIZING THE ISSUANCE OF \$1,000,000  
GENERAL OBLIGATION PROMISSORY NOTES, SERIES 2024-2025E, OF  
GATEWAY TECHNICAL COLLEGE DISTRICT, WISCONSIN

WHEREAS, Gateway Technical College District, Wisconsin (the "District") is presently in need of \$1,000,000 for the public purpose of financing building remodeling and improvement projects; and

WHEREAS, the District hereby finds and determines that the project is within the District's power to undertake and serve a "public purpose" as that term is defined in Section 67.04(a)(b), Wisconsin Statutes; and

WHEREAS, the District Board deems it necessary and in the best interest of the District to borrow the monies needed for such purpose through the issuance of general obligation promissory notes pursuant to the provisions of Section 67.12(12), Wis. Stats.;

NOW, THEREFORE, BE IT:

RESOLVED, that the District shall issue general obligation promissory notes in the amount of \$1,000,000 for the public purpose of financing building remodeling and improvement projects (the "Project"); and be it further

RESOLVED, THAT:

Section 1. Note Authorization. The District shall issue the general obligation promissory notes authorized above in the aggregate principal amount of \$1,000,000 and designated "General Obligation Promissory Notes, Series 2024-2025E" (the "Notes"), the proceeds of which shall be used for the purpose specified above.

Section 2. Notice to Electors. The Secretary shall, within ten (10) days hereafter, cause public notice of the adoption of this resolution to be given to the electors of the District by publishing notices thereof in the Elkhorn Independent, Kenosha News and The Journal Times, the official District newspapers published and having general circulation in the District, which newspapers are found and determined to be likely to give notice to the electors, such notice to be in substantially the form set forth on Exhibit A (the "Notice") hereto.

Section 3. Official Statement. The Secretary shall cause an Official Statement to be prepared by Robert W. Baird & Co. Incorporated. The appropriate District officials shall determine when the Official Statement is final for purposes of Securities and Exchange Commission Rule 15c2-12 and shall certify said Statement, such certification to constitute full authorization of such Official Statement under this resolution.

Section 4. Expenditure of Funds and Declaration of Official Intent. The District shall make expenditures as needed from its funds on hand to pay the cost of the Project until proceeds of the Notes become available. The District hereby officially declares its intent under Treas. Reg. Section 1.150-2 to reimburse said expenditures with proceeds of the Notes, the principal amount of which is not expected to exceed \$1,000,000.

Section 5. Conflicting Resolutions; Severability; Effective Date. All prior resolutions, rules or other actions of the District Board or any parts thereof in conflict with the provisions hereof shall be, and the same are, hereby rescinded insofar as the same may so conflict. In the event that any one or more provisions hereof shall for any reason be held to be illegal or invalid, such illegality or invalidity shall not affect any other provisions hereof. The foregoing shall take effect immediately upon adoption and approval in the manner provided by law. If any of the Notes may be subject to a petition for referendum, any action with respect to the sale of the Notes shall be subject to the condition that no petition for referendum has been filed within thirty (30) days of publication of the Notice provided for under Section 2 of this Resolution or, if a petition is filed, that any required referendum approval is obtained.

Adopted this 20th day of February, 2025.

---

Jason Tadlock  
Chairperson

Attest:

---

Nicole Oberlin  
Secretary

(SEAL)



EXHIBIT A

NOTICE

TO THE ELECTORS OF:

Gateway Technical College  
District, Wisconsin

NOTICE IS HEREBY GIVEN that the District Board of the above-named District, at a meeting duly called and held on February 20, 2025, adopted pursuant to the provisions of Section 67.12(12) of the Wisconsin Statutes, a resolution providing that the sum of \$1,000,000 be borrowed through the issuance of general obligation promissory notes of the District for the public purpose of financing building remodeling and improvement projects.

A copy of said resolution is on file in the District Office, 3520 30th Avenue, Kenosha, Wisconsin, and is available for public inspection weekdays, except holidays, between the hours of 8:00 A.M. and 4:00 P.M. or in the alternative by contacting Theresa Phrakousonh at the District by email at the following address: [phrakousonht@gtc.edu](mailto:phrakousonht@gtc.edu).

The District Board need not submit said resolution to the electors for approval unless within 30 days after the publication of this Notice there is filed with the Secretary of the District Board a petition meeting the standards set forth in Sec. 67.12(12)(e)5, Wis. Stats., requesting a referendum thereon at a special election.

Dated February 20, 2025.

BY ORDER OF THE DISTRICT BOARD

District Secretary

# GATEWAY TECHNICAL COLLEGE DISTRICT BOARD

Roll Call	_____
Action	<u>X</u> _____
Information	_____
Discussion	_____

## **RESOLUTION NUMBERS B-2025 A.1 and A.2 APPROVAL OF PROJECT FOR THE NORTH BUILDING TOILET ROOM AND OFFICE REMODEL – ELKHORN CAMPUS**

**Summary of Item:** The administration is recommending approval by the Gateway Technical College District Board of Resolution Numbers B-2025 A.1 and A.2 for the North Building Toilet Room and Office Remodel Project, Elkhorn WI

The administration also recommends approval from the Wisconsin Technical College System (WTCS) Board for the North Building Toilet Room and Office Remodel Project, Elkhorn WI.

**Attachments:** Resolution Numbers B-2025 A.1 and A.2  
Request for WTCS Board Approval of Project

**Ends Statements and/or**

**Executive Limitations:** Section 3 - Executive Limitation, Financial Condition Policy 3.5  
Section 4 – Ends, College Ends Policy 4.1

**Staff Liaison:** Sharon Johnson

**GATEWAY TECHNICAL COLLEGE**

**RESOLUTION NO. B-2025 A.1**

**WHEREAS**, the Gateway Technical College District Board is proposing the project for the North Building Toilet Room and Office Remodel, Elkhorn, WI will be designed and engineered, focusing on water efficiency, energy and atmosphere, material and resources and indoor environmental quality.

**WHEREAS**, the North Building Toilet Room and Office Remodel Project, Elkhorn, WI, consists of 635 square feet restroom space and 515 square feet of office space. The project cost is estimated at \$500,000.

**NOW, THEREFORE, BE IT RESOLVED** that the Gateway Technical College Board, pursuant to 5.04(2)(a) of the Wisconsin Administrative Code, approves said project.

---

Jason Tadlock  
Chairperson

---

Nicole Oberlin  
Secretary

---

February 20, 2025  
Date

**GATEWAY TECHNICAL COLLEGE**

**RESOLUTION NO. B-2025 A.2**

**WHEREAS**, pursuant to 5.04(4)(a) of the Wisconsin Administrative Code, the Gateway Technical College District Board has approved the Elkhorn Campus, North Building Toilet Room and Office Remodel project consists of 635 square feet restroom space and 515 square feet of office space and will be designed and engineered with WTCS Board Policy 706, Sustainable Facilities, policy intent in mind. The project cost is estimated at \$500,000.

**NOW, THEREFORE, BE IT RESOLVED**, that pursuant to 5.04(4)(a) of the Wisconsin Administrative Code, the Gateway Technical College Board requests the Wisconsin Technical College System Board approve the project.

---

Jason Tadlock  
Chairperson

---

Nicole Oberlin  
Secretary

---

February 20, 2025  
Date

# REQUEST FOR APPROVAL

## REMODELING

Wisconsin Technical College System Board

### **Project Title and Description:**

Elkhorn Campus North Building Restroom and Office Remodel

Gateway Technical College's Elkhorn Campus proposes to remodel approximately 635 square feet of restroom space and 515 square feet of office space in the North Building. The intent of this project is to remodel the existing restrooms and office space as they have aged beyond their useful life.

**District:** Gateway Technical College

**Authorized Representative:** Andrew S Kallenbach

**Date Submitted:** January 24<sup>th</sup>, 2025

**Date of Requested WTCSB Action:** March 12<sup>th</sup>, 2025

## Remodel Justification

Gateway Technical College proposes to remodel approximately 635 square feet of restroom space, and 515 square feet of office space in the North Building of the Elkhorn Campus.

The existing bathrooms have not seen major improvements in over 25 years. The proposed remodel will provide a clean, functional and well-lit space for the staff and students who utilize the facility. The existing office has not seen any improvements in over 25 years. The remodel of this space would address some water infiltration issues and provide needed additional space and a private office for the dual credit program. The proposed project would also allow Gateway Technical College to capture more energy efficiency as well as bring the spaces into ADA compliance.



**Partners in Design**  
ARCHITECTS

**Partners in Design  
Architects, Inc.**

**W I S C O N S I N**  
600 Fifty Second Street  
Suite 220  
Kenosha, WI 53140  
262.652.2800

**I L L I N O I S**  
2610 Lake Cook Road  
Suite 280  
Riverwoods, IL 60015  
847.940.0300

January 13, 2025

Mr. Andrew Kallenbach  
Gateway Technical College  
Director of Construction and Facilities  
3520 30<sup>th</sup> Avenue  
Kenosha, Wisconsin 53144

RE: Elkhorn Campus  
North Building Toilet Room and Office Remodel  
400 County Road H, Elkhorn, WI

**Dear Mr. Kallenbach:**

In response to WTCS Board Policy 706, Sustainable Facilities, I confirm that the North Building Toilet Room and Office remodel project will be designed and engineered with the intent of this policy in mind. For your review and an explanation of our goal, we will follow the guidelines set in LEED 2009 for BD+C: New Construction and Major Renovation. We will focus on the following categories: Water Efficiency, Energy and Atmosphere, Materials and Resources, and Indoor Environmental Quality.

Recognizing that Gateway will not be certifying the building through the U.S. Green Building Council (USGBC) and that the USGBC makes the final decision regarding awarding points, we cannot definitively provide a point range for the remodel's design.

Sincerely,

Jeffrey E. Bridleman, AIA

[www.pidarchitects.com](http://www.pidarchitects.com)

**P A S S I O N C O L L A B O R A T I O N V I S I O N**



# LEED 2009 for New Construction and Major Renovations

## Project Checklist

GTC Elkhorn N. Building Toilet Room and Office Remodel

12.13.25

26 Sustainable Sites		Possible Points: 26	
Y	?	N	
Y			Prereq 1 Construction Activity Pollution Prevention
	1		Credit 1 Site Selection
	5		Credit 2 Development Density and Community Connectivity
	1		Credit 3 Brownfield Redevelopment
	6		Credit 4.1 Alternative Transportation—Public Transportation Access
	1		Credit 4.2 Alternative Transportation—Bicycle Storage and Changing Rooms
	3		Credit 4.3 Alternative Transportation—Low-Emitting and Fuel-Efficient Vehicles
	2		Credit 4.4 Alternative Transportation—Parking Capacity
	1		Credit 5.1 Site Development—Protect or Restore Habitat
	1		Credit 5.2 Site Development—Maximize Open Space
	1		Credit 6.1 Stormwater Design—Quantity Control
	1		Credit 6.2 Stormwater Design—Quality Control
	1		Credit 7.1 Heat Island Effect—Non-roof
	1		Credit 7.2 Heat Island Effect—Roof
	1		Credit 8 Light Pollution Reduction

22 Water Efficiency		Possible Points: 10	
Y	?	N	
Y	4		Prereq 1 Water Use Reduction—20% Reduction
	2		Credit 1 Water Efficient Landscaping
	2		Credit 2 Innovative Wastewater Technologies
	2		Credit 3 Water Use Reduction

107 Energy and Atmosphere		Possible Points: 35	
Y	?	N	
Y	4		Prereq 1 Fundamental Commissioning of Building Energy Systems
Y	7		Prereq 2 Minimum Energy Performance
Y	7		Prereq 3 Fundamental Refrigerant Management
	4		Credit 1 Optimize Energy Performance
	7		Credit 2 On-Site Renewable Energy
	2		Credit 3 Enhanced Commissioning
	2		Credit 4 Enhanced Refrigerant Management
	3		Credit 5 Measurement and Verification
	2		Credit 6 Green Power

93 Materials and Resources		Possible Points: 14	
Y	?	N	
Y	1		Prereq 1 Storage and Collection of Recyclables
	1		Credit 1.1 Building Reuse—Maintain Existing Walls, Floors, and Roof
	1		Credit 1.2 Building Reuse—Maintain 50% of Interior Non-Structural Elements
	2		Credit 2 Construction Waste Management
	2		Credit 3 Materials Reuse

Materials and Resources, Continued		Possible Points: 15	
Y	?	N	
	2		Credit 4 Recycled Content
	2		Credit 5 Regional Materials
	1		Credit 6 Rapidly Renewable Materials
	1		Credit 7 Certified Wood

87 Indoor Environmental Quality		Possible Points: 15	
Y	?	N	
Y			Prereq 1 Minimum Indoor Air Quality Performance
Y			Prereq 2 Environmental Tobacco Smoke (ETS) Control
	1		Credit 1 Outdoor Air Delivery Monitoring
	1		Credit 2 Increased Ventilation
	1		Credit 3.1 Construction IAQ Management Plan—During Construction
	1		Credit 3.2 Construction IAQ Management Plan—Before Occupancy
	1		Credit 4.1 Low-Emitting Materials—Adhesives and Sealants
	1		Credit 4.2 Low-Emitting Materials—Paints and Coatings
	1		Credit 4.3 Low-Emitting Materials—Flooring Systems
	1		Credit 4.4 Low-Emitting Materials—Composite Wood and Agrifiber Products
	1		Credit 5 Indoor Chemical and Pollutant Source Control
	1		Credit 6.1 Controllability of Systems—Lighting
	1		Credit 6.2 Controllability of Systems—Thermal Comfort
	1		Credit 7.1 Thermal Comfort—Design
	1		Credit 7.2 Thermal Comfort—Verification
	1		Credit 8.1 Daylight and Views—Daylight
	1		Credit 8.2 Daylight and Views—Views

15 Innovation and Design Process		Possible Points: 6	
Y	?	N	
	1		Credit 1.1 Innovation in Design: Specific Title
	1		Credit 1.2 Innovation in Design: Specific Title
	1		Credit 1.3 Innovation in Design: Specific Title
	1		Credit 1.4 Innovation in Design: Specific Title
	1		Credit 1.5 Innovation in Design: Specific Title
	1		Credit 2 LEED Accredited Professional

4 Regional Priority Credits		Possible Points: 4	
Y	?	N	
	1		Credit 1.1 Regional Priority: Specific Credit
	1		Credit 1.2 Regional Priority: Specific Credit
	1		Credit 1.3 Regional Priority: Specific Credit
	1		Credit 1.4 Regional Priority: Specific Credit

342452 Total		Possible Points: 110	
Y	?	N	
34	24	52	

Certified 40 to 49 points Silver 50 to 59 points Gold 60 to 79 points Platinum 80 to 110



<b>BURLINGTON CAMPUS BARBER-COSMETOLOGY SUITE</b>		
---	--	--

TCS 5.04(4)(h)	Description	Budget
1	General Construction	\$ 11,100.00
2	Heating, ventilation and AC	\$ 34,000.00
3	Electrical	\$ 29,600.00
4	Plumbing	\$ 99,800.00
5	Other contracts:	
	Demolition	\$ 38,600.00
	Earthwork & Site utilities	\$ -
	Concrete	\$ 5,200.00
	Asphalt Paving	\$ -
	Lanscaping (Allowance)	\$ -
	Masonry	\$ -
	Metals	\$ -
	Woods & Plastic	\$ 7,300.00
	Doors & Windows	\$ 3,800.00
	Finishes	\$ 81,300.00
	Roofing Work	\$ -
	Sealants / Firestopping	\$ 2,800.00
	Fire Protection	\$ -
6	Equipment	\$ -
7	Miscellaneous cost	\$ 25,300.00
	Supervision	\$ 54,600.00
	Contingency	\$ 40,000.00
	General Liability Insurance	\$ 1,000.00
	General Contractor Fees	\$ 11,300.00
	Performance Bond	\$ 4,100.00
8	Fees & Permits	\$ 5,500.00
	<b>TOTAL CONSTRUCTION:</b>	<b>\$ 455,300.00</b>
	Asbestos Abatement & Security Modifications	
	<b>TOTAL OWNER ALLOWANCE:</b>	<b>\$ -</b>
	Architectural & Engineering	\$ 42,000.00
	Reimbursable	\$ 2,700.00
	Commissioning & Arc Flash/Fault Current	\$ -
	<b>TOTAL A&amp;E FEES:</b>	<b>\$ 44,700.00</b>
<b>TOTAL PROJECT COST:</b>		<b>\$ 500,000.00</b>

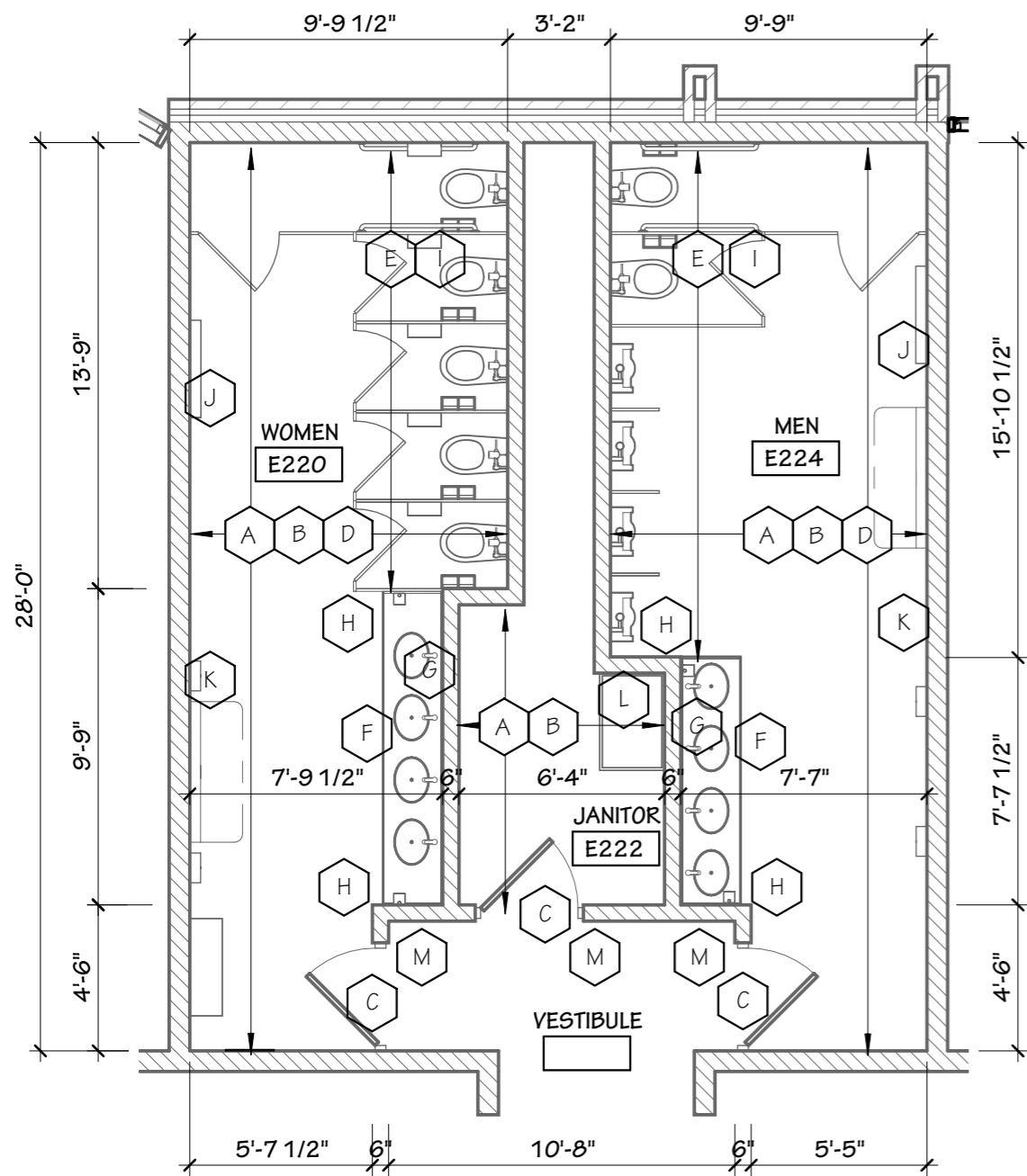

### KEY NOTES

- A EXISTING TILE FLOORING
- B EXISTING TILE WALL FINISH
- C EXISTING DOOR
- D EXISTING HARDBOARD CEILING
- E EXISTING TOILET PARTITIONS AND ACCESSORIES
- F EXISTING EXISTING COUNTERTOP, SINKS & FAUCETS AND ALL ASSOCIATED COMPONENTS
- G EXISTING MIRRORS
- H EXISTING WALL MOUNTED SOAP DISPENSERS
- I EXISTING WALL MOUNTED TOILET/URINAL FIXTURES
- J EXISTING UNIT HEATER
- K EXISTING FIRE ALARM STROBE
- L EXISTING FLOOR BASIN AND FAUCET
- M EXISTING SIGNAGE

### KEYPLAN - NORTH BLDG

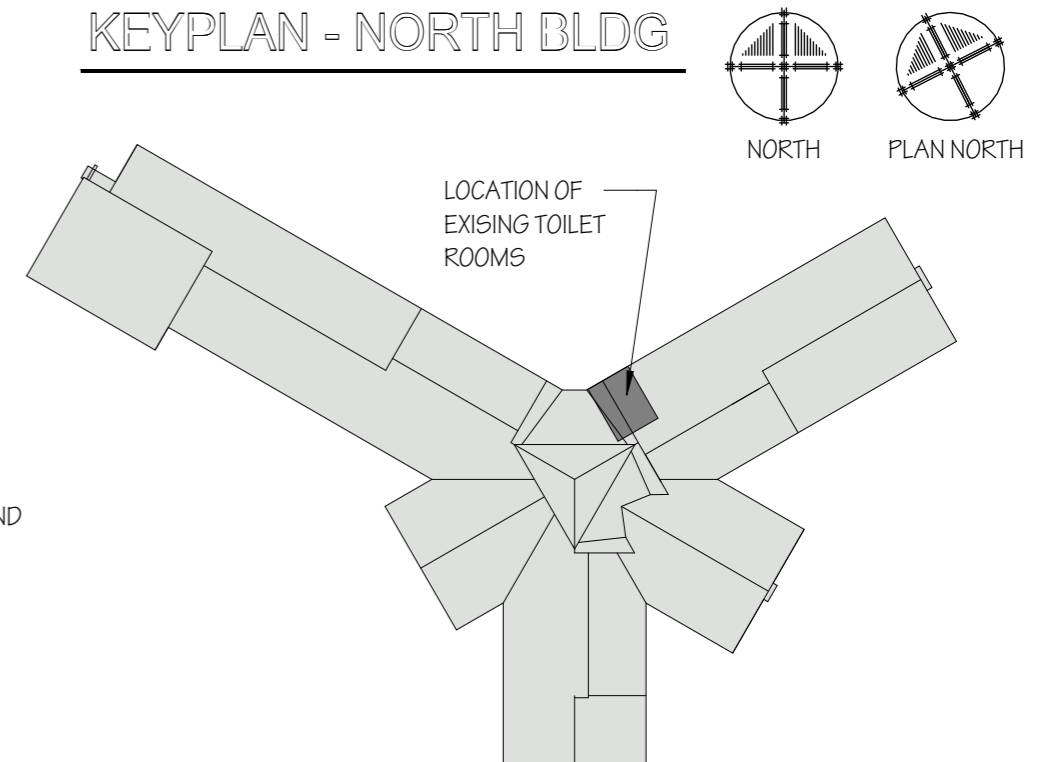

### EXISTING FLOOR PLAN

3/16" = 1'-0"

635 SF

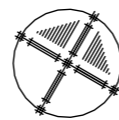

## ELKHORN CAMPUS - NORTH BUILDING

EXISTING TOILET ROOM

EXISTING TOILET ROOM PLAN  
BUDGET  
01.20.2025



**Partners in Design**  
ARCHITECTS

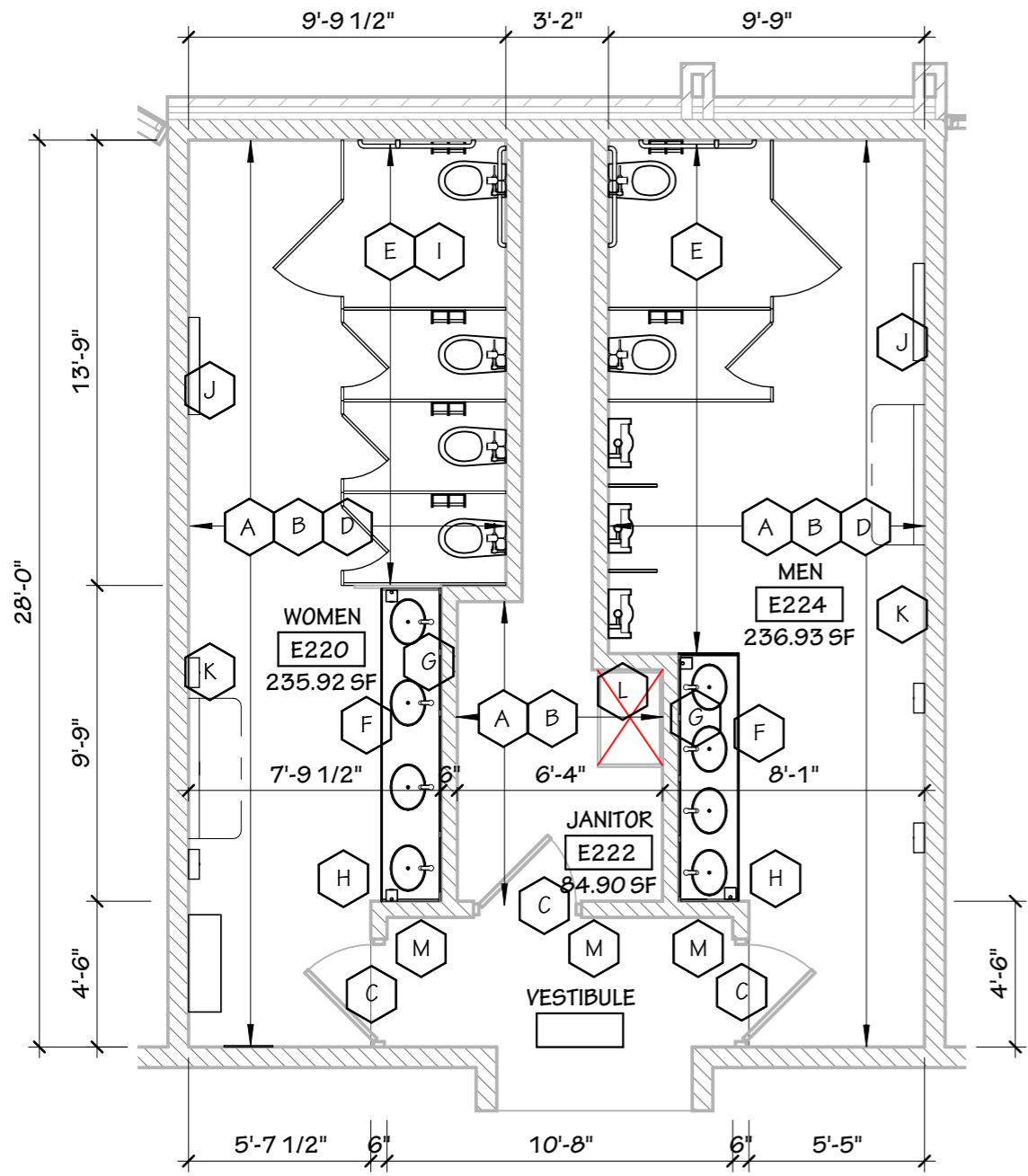

**FLOOR PLAN**

3/16" = 1'-0"

635 SF

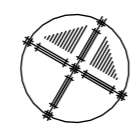

**KEY NOTES**

- A REMOVE TILE FLOOR AND REPLACE WITH NEW TILE FLOOR WITH TILE BASE
- B REMOVE TILE FINISH ON WALLS & REPLACE WITH NEW TILE ON WE WALLS AND PAINTED GYPSUM BOARD ON REMAINING WALLS
- C EXISTING DOOR, FRAME AND HARDWARE ARE TO REMAIN AS IS
- D REMOVE HARD BOARD CEILING AND REPLACE WITH NEW VINYL FACED GYPSUM BOARD SUSPENDED ACOUSTICAL TILE CEILING AND GRID WITH NEW LIGHT FIXTURES
- E REMOVE TOILET PARTITIONS PLASTIC TOILET PARTITIONS AND ACCESSORIES AS NEEDED
- F REMOVE COUNTERTOP, SINKS & FAUCETS AND ALL ASSOCIATED COMPONENTS. REPLACE WITH NEW SOLID SURFACE COUNTER TOP WITH (4) INTEGRATED BOWL SINKS AND FAUCETS
- G REMOVE MIRRORS AND REPLACE WITH NEW ADA COMPLIANT MIRRORS
- H EXISTING TOILET ROOMS HAVE BEEN UPDATED TO HAVE HANDS FREE FIXTURES. SALVAGE PAPER TOWEL DISPENSERS, TOILET PAPER DISPENSERS AND SOAP DISPENSERS FOR REINSTALLATION.
- I REMOVE EXISTING (5) WALL MOUNTED FIXTURES AND REPLACE WITH NEW (4) WALL MOUNTED FIXTURES
- J REPLACE UNIT HEATER AND CONTROLS.
- K REMOVE AND REPLACE FIRE ALARM STROBE
- L REMOVE AND REPLACE FLOOR BASIN AND FAUCET WITH NEW
- M REMOVE AND REPLACE SIGNAGE

**KEYPLAN - NORTH BLDG**

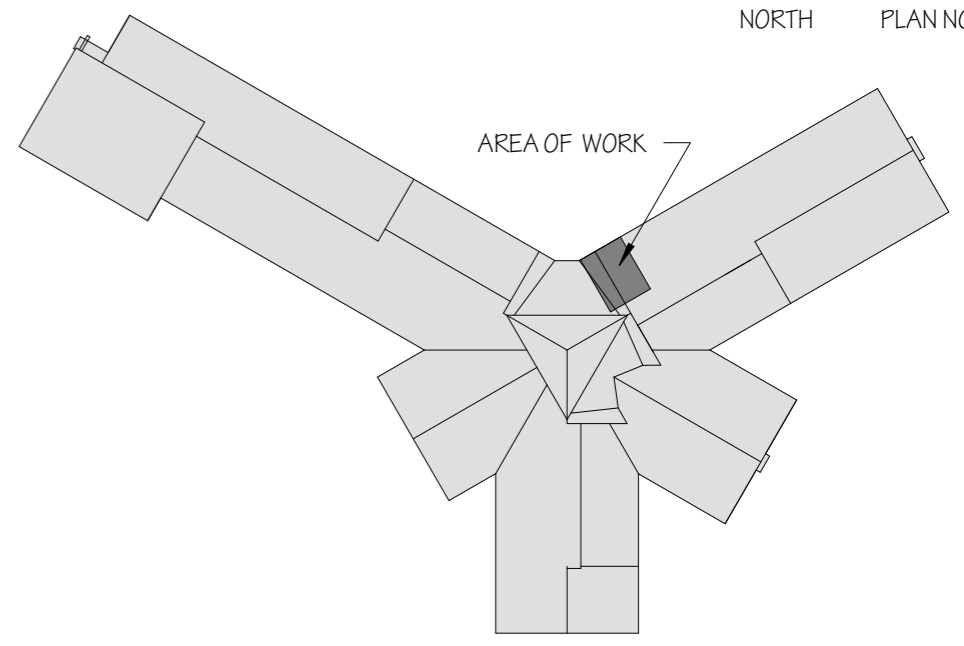
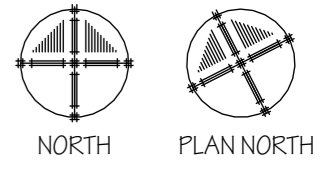

**ELKHORN CAMPUS - NORTH BUILDING**

PROPOSED TOILET ROOM REMODEL

PROPOSED REMODEL  
BUDGET  
01.20.2025



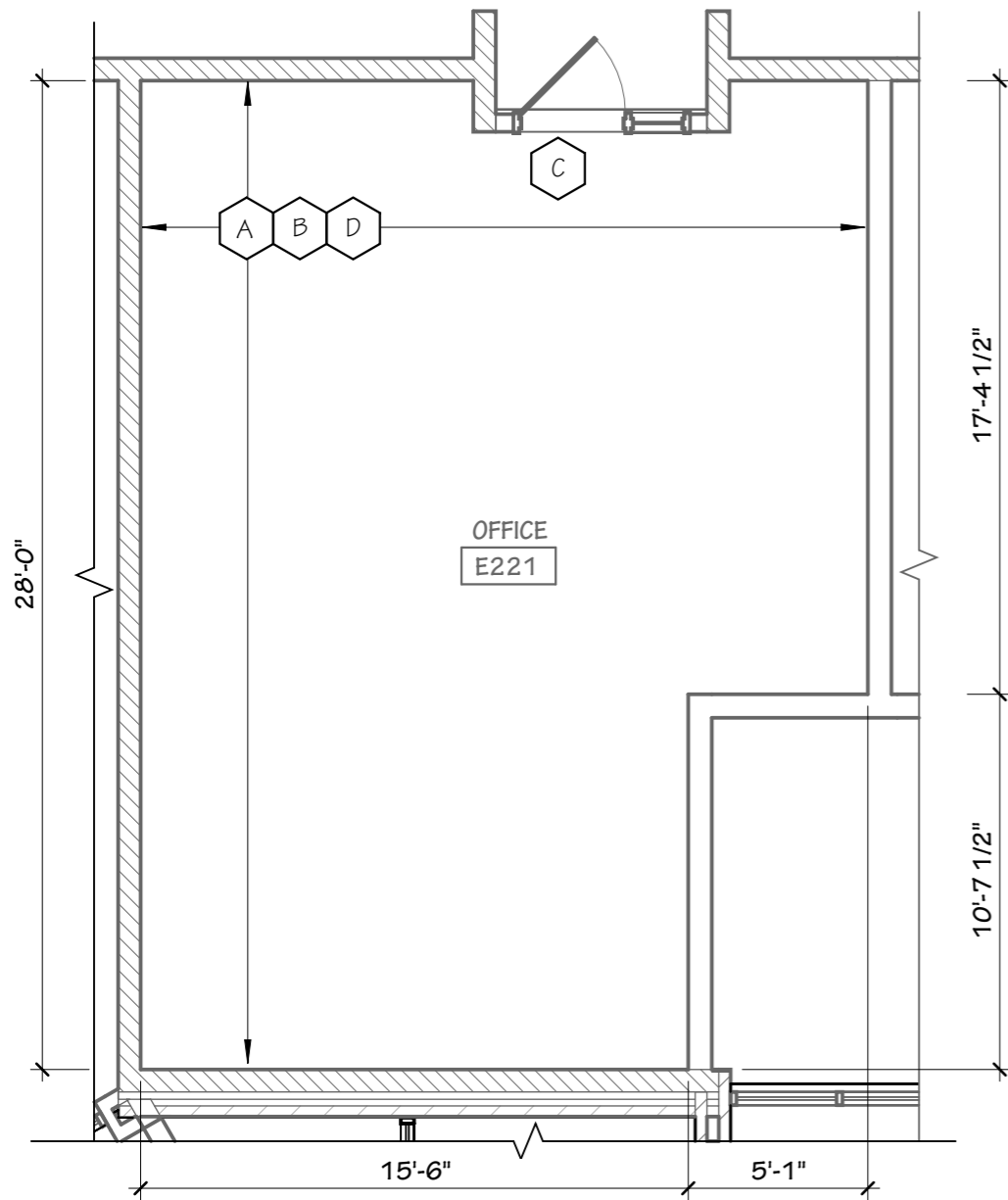

**KEY NOTES**

- A EXISTING CARPET FLOORING
- B EXISTING GYPSUM BOARD WALLS
- C EXISTING DOOR, FRAME AND HARDWARE
- D EXISTING SUSPENDED ACOUSTICAL CEILING TILE AND GRID

**KEYPLAN - NORTH BLDG**

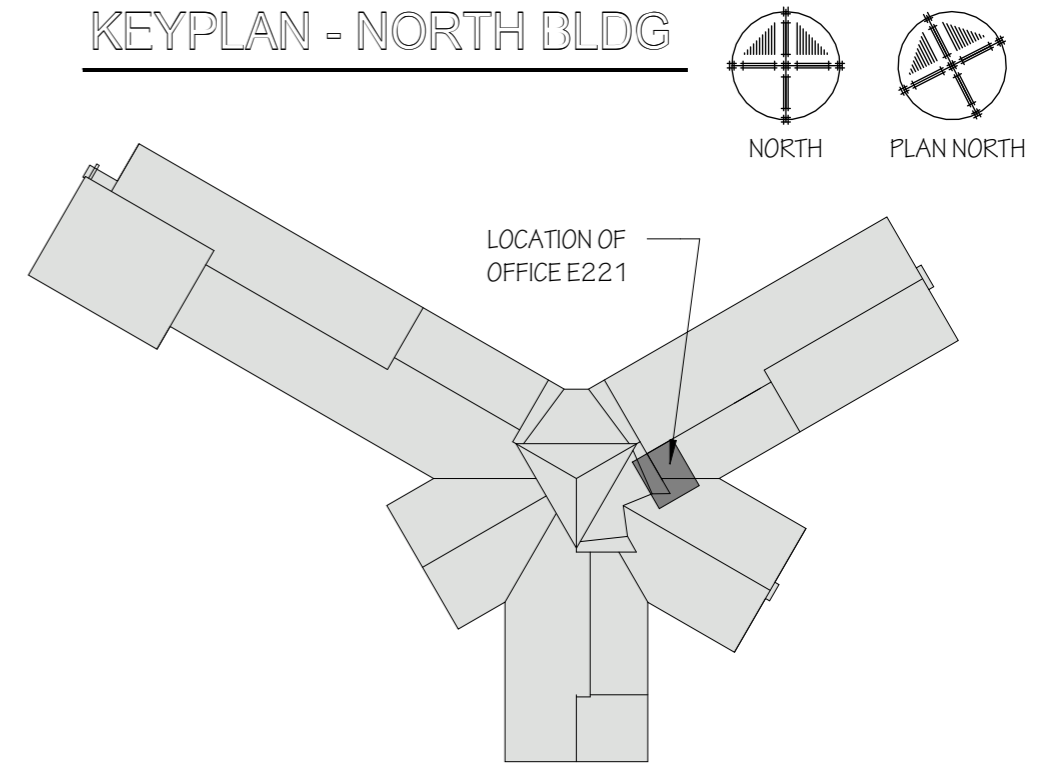

**EXISTING FLOOR PLAN**

3/16" = 1'-0"

5156F

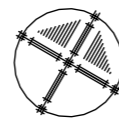

**ELKHORN CAMPUS - NORTH BUILDING**

EXISTING OFFICE - E221



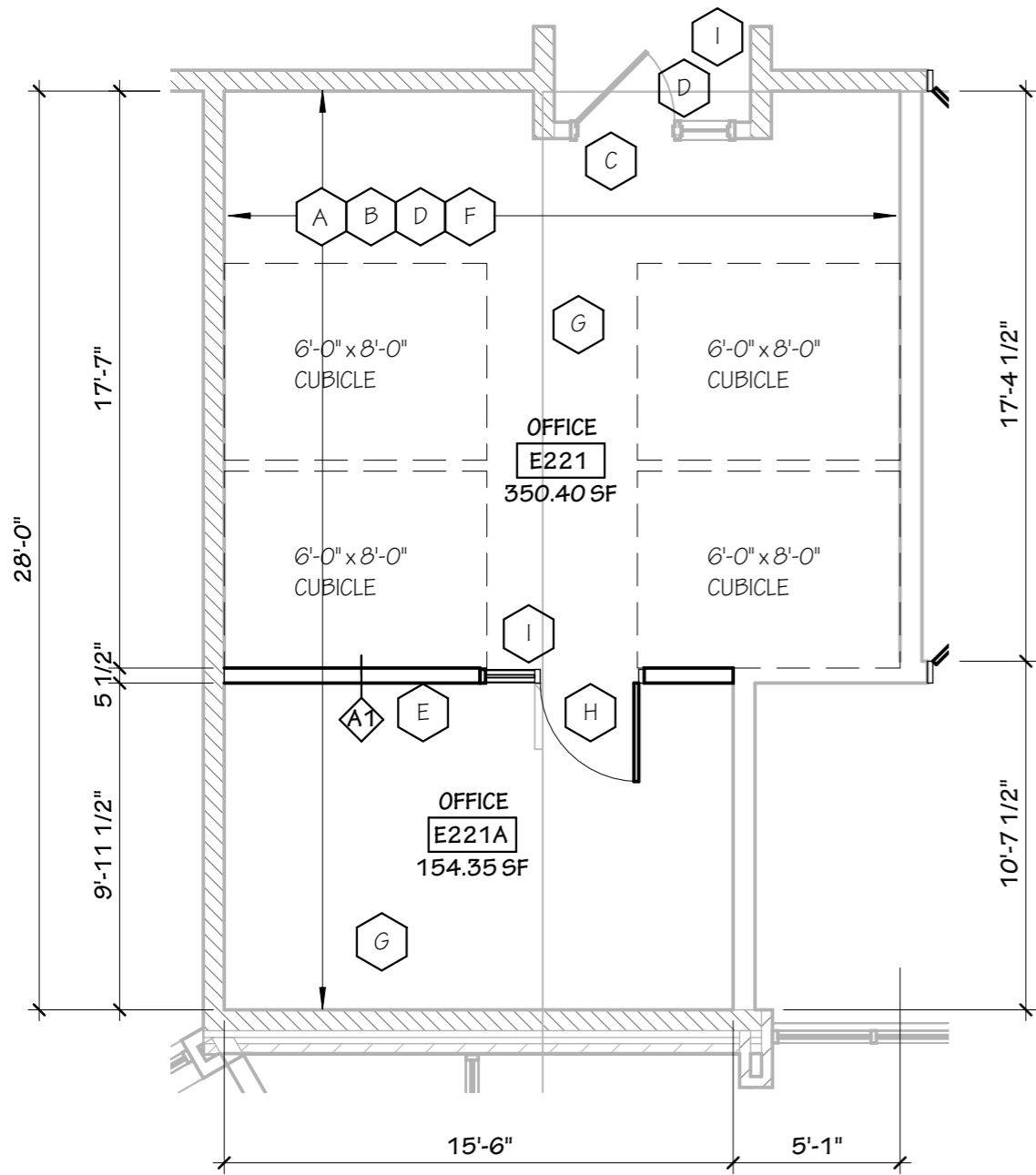

FLOOR PLAN

3/16" = 1'-0"

515 SF

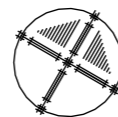

KEY NOTES

- A REMOVE CARPET FLOORING AND REPLACE WITH NEW CARPET TILE AND NEW BASE
- B REMOVE GYPSUM BOARD ON WALLS & REPLACE WITH NEW PAINTED GYPSUM BOARD
- C EXISTING DOOR, FRAME AND HARDWARE TO REMAIN AS IS
- D NEW F.O.B. AT DOOR
- E NEW METAL STUD WALL WITH SOUND BATTING AND GYPSUM BOARD BOTH SIDES, PAINTED
- F REMOVE AND REPLACE EXISTING SUSPENDED ACOUSTICAL CEILING TILE AND GRID AND REPLACE WITH NEW S.A.T. TILE AND GRID, WITH NEW LED LIGHT FIXTURES
- G NEW FURNITURE
- H NEW WOOD DOOR WITH SIDELITE AND METAL FRAME
- I NEW SIGNAGE

KEYPLAN - NORTH BLDG

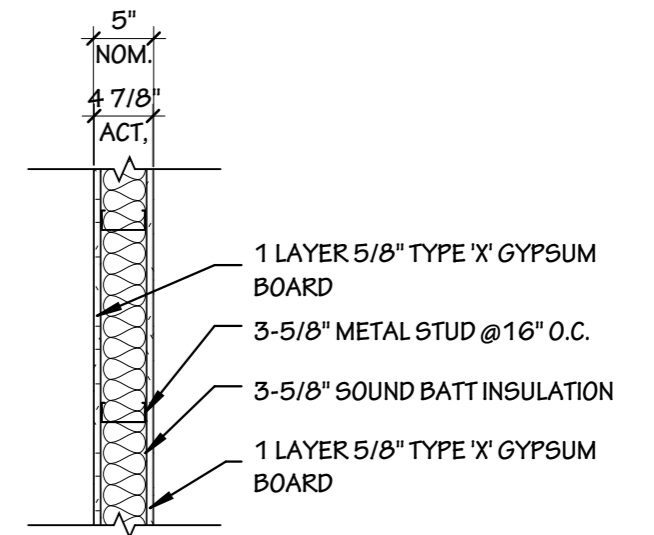
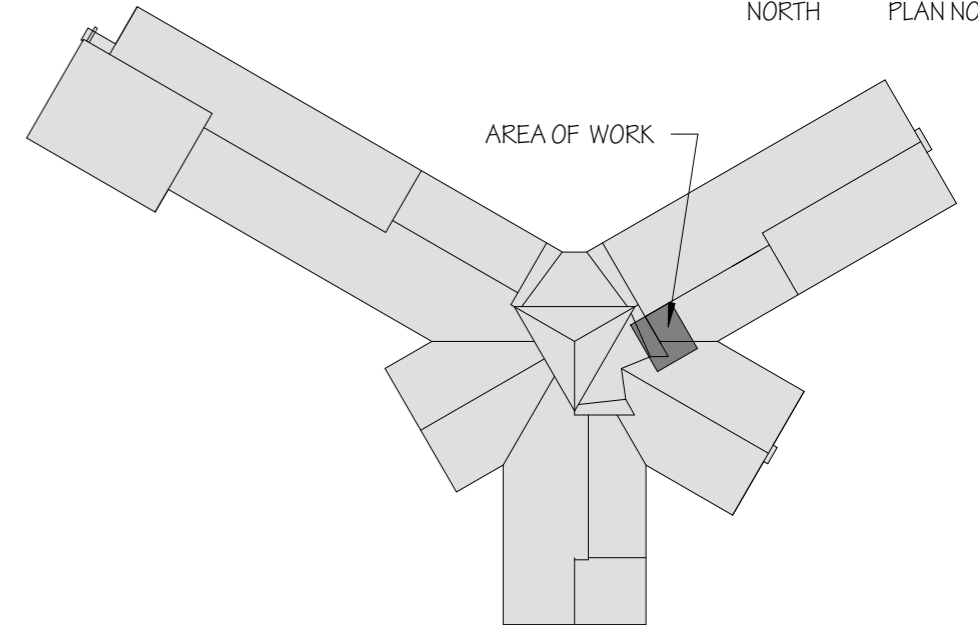
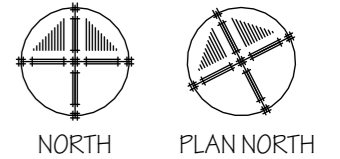

ELKHORN CAMPUS - NORTH BUILDING

PROPOSED OFFICE REMODEL - E221



## OPERATIONAL AGENDA

### B) Consent Agenda

- 1) Bid No. 1732
- 2) Finance
  - a. Summary of Revenues and Expenditures
  - b. Cash and Investment Schedules
- 3) Personnel Report
- 4) Contracts for Instructional Delivery
  - a. Business and Workforce Solutions
  - b. Protective Services
  - c. High School
- 5) Advisory Committee Activity Report

**GATEWAY TECHNICAL COLLEGE DISTRICT BOARD**

Roll Call \_\_\_\_\_  
Action  \_\_\_\_\_  
Information \_\_\_\_\_  
Discussion \_\_\_\_\_

**BID NO. 1732  
TECH BUILDING TUCKPOINTING  
RACINE CAMPUS**

Summary of Item: Sealed bids were received from various subcontractors for the Tech Building Tuckpointing Project - Racine Campus.

The administration is recommending the contract to provide all labor and materials required for this project be award to:

**Camosy Construction  
Kenosha WI**

Construction Contract: (Camosy's Contract)	\$	459,696.00
A&E Fees: (PIDA fee 9.25%)	\$	42,522.00
Reimbursable Fees:	\$	140.00
Owner-held Contingency:	\$	15,000.00
<b>Total Project Cost:</b>		<b>\$ 517,358.00</b>

Funding Source: G O Promissory Notes Series 2024-2025B

Attachments: Letter of Recommendation for Award of Bid and Tabulation of Bids from Partners In Design Architects

Ends Statements and/or

Executive Limitations: Section 3 - Executive Limitation, Financial Condition Policy 3.5

Staff Liaison: Sharon Johnson

Top1120.docx or pdf. 02/20/2025



February 6, 2025

Sharon Johnson  
Gateway Technical College  
3520 30<sup>th</sup> Avenue  
Kenosha, Wisconsin 53140

RE: Racine Campus  
Tech Building Tuckpointing  
Official Notice No. 1732

**Dear Mrs. Johnson:**

On Thursday, January 23, 2025, at the office of your construction manager, Camosy Construction, subcontractor bids were received and opened for the Tech Building Tuckpointing project. Rhonda Cerminara and Andrew Kallenbach were in attendance on behalf of Gateway Technical College. Tyler Thiel was in attendance on behalf of Camosy Construction. Jeremy Busch and Mike Pillizzi attended on behalf of Partners in Design Architects.

Since the bid day, Partners in Design Architects has been working with Camosy Construction and Gateway Technical College to evaluate and clarify the bid day numbers. We recommend that the alternate work be accepted.

Based on our bid evaluation and clarifications, we recommend that Camosy Construction's contract value be \$459,696.00 for the Tech Building Tuckpointing project. Gateway Technical College should also budget approximately \$42,522.00 for architectural and engineering fees and \$140.00 for reimbursable costs related to printing fees. We also recommend the college hold a \$15,000.00 contingency for hourly services performed during the construction observation phase by Leonardelli Engineering.

Contract:	\$	459,696.00	(Camosy's Contract)
A&E Fees:	\$	42,522.00	(PIDA fee 9.25%)
Reimbursable Fees:	\$	140.00	
<u>Owner-held contingency:</u>	<u>\$</u>	<u>15,000.00</u>	
Total Project Cost:	\$	517,358.00	

Should you have any questions regarding our recommendation, please do not hesitate to call me.

Sincerely,

Jeffrey E. Bridleman, AIA, ALA



PIDA Proj. No.	191.23.125		
GTC Proj No.	Official No. 1732		
Proj Name	Racine Campus Tech Building Tuckpointing		
Total Project Budget		\$	400,000.00

Accepted or Not	General Contractor		
<b>Recommend</b>	<b>Camosy GMP</b>	\$	360,611.00
	<b>Alternate Bid No. 1</b>	\$	99,085.00
<b>Construction Total</b>		\$	459,696.00

	A&E Fees - Estimated Hourly Fees		
Study Fees			
Camosy GMP	9.25%	\$	33,357.00
Alt. Bid No. 1	9.25%	\$	9,165.00
		\$	-
<b>Sub-Total Fees</b>		\$	42,522.00
	Printing Cost: Bidding	\$	140.00
	Printing Cost: For Construction	\$	-
<b>Sub-Total Reimbursable</b>		\$	140.00
<b>A&amp; E Total fees</b>		\$	42,662.00

	GTC Responsible fees		
	Asbestos Abatement	\$	-
	Fiber Relocation	\$	-
	HVAC Commissioning	\$	-
	Telephone Service modifications	\$	-
	PerMar Security modifications	\$	-
	Entry Technology modifications	\$	-
	Graphic Signage	\$	-
	Testing Services	\$	-
	Building Permit Fees	\$	-
	Kenosha Registrar of Deeds	\$	-
	Impact fees	\$	-
	Environmental Impact fees	\$	-
	Contingency Fee held by GTC	\$	-
	Signage budget	\$	-
	Leonardelli Engineering, Inc. - Additional service Hourly NTE \$15k	\$	15,000.00
<b>GTC Project Cost</b>		\$	15,000.00

<b>Total Project Cost</b>		\$	517,358.00
---------------------------	--	----	------------

budget vs. actual bid cost difference: \$ (117,358.00)

**GTC - Racine Campus**  
**Tech Building Facade Repairs**  
**BID DAY**

**GMP**



0122-24 ISSUED FOR BID

31-Jan-25

ITEM	DESCRIPTION	GMP
1.00	GENERAL CONDITIONS	\$5,922
2.00	PRECONSTRUCTION SERVICES	\$2,298
1.10	TEMPORARY FENCE ALLOWANCE <i>ALLOW</i>	\$5,000
1.20	ROOFING ALLOWANCE <i>ALLOW</i>	\$15,000
1.30	ELECTRICAL ALLOWANCE <i>ALLOW</i>	\$5,000
4.00	B.P. #4.00 - MASONRY & TUCKPOINTING	\$250,000
4.01	ALTERNATE #1 WORK	\$95,000
18.00	TESTING <i>NIC</i>	\$0
19.00	PERMIT <i>NIC</i>	\$0
24.00	OWNERS CONTINGENCY	\$50,000
27.00	INSURANCE	\$1,104
28.00	FIELD SUPERVISION	\$17,041
29.00	CONSTRUCTION FEE	\$9,194
30.00	BOND PREMIUM	\$4,137
<b>GMP</b>		<b>\$459,696</b>

UP - #2	MASONRY - CRACK REPAIRING	<i>LF Allowance</i>	\$75 <i>PER LF</i>
UP - #3	MASONRY - REPOINTING	<i>SF Allowance</i>	\$20 <i>PER SF</i>
UP - #4	MASONRY - REBUILDING SINGLE-WYTHE	<i>SF Allowance</i>	\$100 <i>PER SF</i>
UP - #5	MASONRY - REBUILDING DOUBLE-WYTHE	<i>SF Allowance</i>	\$300 <i>PER SF</i>
UP - #6	MASONRY - BRICK EXPANSION JOINT	<i>LF Allowance</i>	\$170 <i>PER LF</i>
UP - #7	CONCRETE - RAILING ANCHORAGE	<i>EA Allowance</i>	\$1,200 <i>PER EA</i>
UP - #8	CONCRETE - SPALLING	<i>SF Allowance</i>	\$375 <i>PER SF</i>
UP - #9	STEEL - CLEANING & COATING	<i>LF Allowance</i>	\$21 <i>PER LF</i>
UP - #10	SEALANTS - JOINT SEALANT REPLACEMENT	<i>LF Allowance</i>	\$14 <i>PER LF</i>

Gateway Technical College - Racine Campus - Tech Building Facade Repairs										
Project:	Camosy Construction - Tyler Thiel									
Project No.:	#1732									
GIC P.O.:	12795 120th Avenue, Menasha, WI 53142									
Thursday, January 23rd, 2025 @ 2:00PM										
Package No.	Description	Awarded Bidder	Other Bidder(s)	Date Received	Time Received	Base Bid Amount	Alternate #1 Amount	Voluntary/Alternate #1	Voluntary Alternate #2	BASE BID & ALTERNATE #1 CONTRACT AMOUNT
4.00	Masonry Work & Tuckpointing	Berglund Construction Company	N/A	1/23/2025	1:57 PM	\$250,000.00	\$95,000.00	\$0.00	\$0.00	\$345,000.00
				N/A	N/A	\$0.00	\$0.00	\$0.00	\$0.00	\$0.00
									GRAND TOTAL CONTRACT AMOUNT	\$345,000.00

THIS COLOR INDICATES THE TOTAL CONTRACT AMOUNT FOR EACH PACKAGE & THE PROJECT.

# GATEWAY TECHNICAL COLLEGE DISTRICT BOARD

Roll Call  
Action X  
Information  
Discussion

## SUMMARY OF REVENUE AND EXPENDITURES

**Summary of Item:** Summary of revenue and expenditures as of 01/31/25

Ends Statements and/or Executive Limitations  
Section 3 - Executive Limitations  
Policy 3.5 Financial Condition

**Staff Liaison:** Sharon Johnson

**GATEWAY TECHNICAL COLLEGE**  
**2024-25 SUMMARY OF REVENUE & EXPENDITURES AS OF 01/31/2025**

<u>COMBINED FUNDS</u>	2024-25 APPROVED BUDGET	2024-25 WORKING BUDGET	2024-25 ACTUAL TO DATE	PERCENT INCURRED
<b>REVENUE:</b>				
LOCAL GOVERNMENT	\$ 41,429,737	\$ 41,429,737	\$ 41,423,549	99.99%
STATE AIDS	51,706,681	51,706,681	7,691,182	14.87%
STATUTORY PROGRAM FEES	14,654,327	14,654,327	15,130,301	103.25%
MATERIAL FEES	869,077	869,077	896,914	103.20%
OTHER STUDENT FEES	2,746,735	2,746,735	2,477,997	90.22%
INSTITUTIONAL	11,697,218	11,697,218	7,419,385	63.43%
FEDERAL	25,457,728	25,457,728	11,492,381	45.14%
OTHER RESOURCES	12,373,290	12,373,290	10,558,520	85.33%
<b>TOTAL REVENUE &amp; OTHER RESOURCES</b>	<u>\$ 160,934,793</u>	<u>\$ 160,934,793</u>	<u>\$ 97,090,229</u>	60.33%
<b>EXPENDITURES BY FUNCTION:</b>				
INSTRUCTIONAL	\$ 72,258,393	\$ 71,977,818	\$ 35,816,907	49.76%
INSTRUCTIONAL - RESOURCES	1,265,126	1,265,126	702,037	55.49%
STUDENT SERVICES	41,060,541	41,007,971	22,916,395	55.88%
GENERAL INSTITUTIONAL	13,623,773	13,603,773	7,966,000	58.56%
PHYSICAL PLANT	32,270,865	32,245,596	11,621,853	36.04%
AUXILIARY SERVICES	700,000	700,000	454,549	64.94%
PUBLIC SERVICE	455,941	455,941	223,936	49.12%
<b>TOTAL EXPENDITURES</b>	<u>\$ 161,634,639</u>	<u>\$ 161,256,225</u>	<u>\$ 79,701,678</u>	49.43%
<b>EXPENDITURES BY FUNDS:</b>				
GENERAL	\$ 91,990,010	\$ 91,990,010	\$ 49,830,911	54.17%
SPECIAL REVENUE - OPERATIONAL	11,838,686	11,506,894	4,683,300	40.70%
SPECIAL REVENUE - NON AIDABLE	25,983,031	25,983,031	14,673,794	56.47%
CAPITAL PROJECTS	13,731,622	13,685,000	7,908,446	57.79%
DEBT SERVICE	17,391,290	17,391,290	2,150,676	12.37%
ENTERPRISE	700,000	700,000	454,549	64.94%
<b>TOTAL EXPENDITURES</b>	<u>\$ 161,634,639</u>	<u>\$ 161,256,225</u>	<u>\$ 79,701,678</u>	49.43%

**GATEWAY TECHNICAL COLLEGE**  
**2024-25 SUMMARY OF REVENUE & EXPENDITURES AS OF 01/31/2025**

<u>GENERAL FUND</u>	2024-25 APPROVED BUDGET	2024-25 WORKING BUDGET	2024-25 ACTUAL TO DATE	PERCENT INCURRED
<b>REVENUE:</b>				
LOCAL GOVERNMENT	\$ 22,281,737	\$ 22,281,737	\$ 22,275,549	99.97%
STATE AIDS	44,129,279	44,129,279	5,952,163	13.49%
STATUTORY PROGRAM FEES	14,654,327	14,654,327	15,130,301	103.25%
MATERIAL FEES	869,077	869,077	896,914	103.20%
OTHER STUDENT FEES	1,636,522	1,636,522	1,377,095	84.15%
FEDERAL	20,000	20,000	155	0.78%
INSTITUTIONAL	8,430,358	8,430,358	3,584,986	42.52%
OTHER RESOURCES	<u>-</u>	<u>-</u>	<u>-</u>	
TOTAL REVENUE & OTHER RESOURCES	<u>\$ 92,021,300</u>	<u>\$ 92,021,300</u>	<u>\$ 49,217,163</u>	53.48%
<b>EXPENDITURES BY FUNCTION:</b>				
INSTRUCTIONAL	\$ 60,108,737	\$ 60,108,737	\$ 30,767,310	51.19%
INSTRUCTIONAL - RESOURCES	1,245,126	1,245,126	702,037	56.38%
STUDENT SERVICES	13,009,449	13,009,449	7,083,763	54.45%
GENERAL INSTITUTIONAL	9,822,392	9,822,392	5,753,786	58.58%
PHYSICAL PLANT	<u>7,804,306</u>	<u>7,804,306</u>	<u>5,524,016</u>	70.78%
TOTAL EXPENDITURES	<u>\$ 91,990,010</u>	<u>\$ 91,990,010</u>	<u>\$ 49,830,911</u>	54.17%

**GATEWAY TECHNICAL COLLEGE**  
**2024-25 SUMMARY OF REVENUE & EXPENDITURES AS OF 01/31/2025**

<u>SPECIAL REVENUE-OPERATIONAL FUND</u>	2024-25 APPROVED BUDGET	2024-25 WORKING BUDGET	2024-25 ACTUAL TO DATE	PERCENT INCURRED
<b>REVENUE:</b>				
LOCAL GOVERNMENT	\$ 2,000,000	\$ 2,000,000	\$ 2,000,000	100.00%
STATE AIDS	4,043,802	4,043,802	701,654	17.35%
FEDERAL	5,247,660	5,247,660	222,893	4.25%
INSTITUTIONAL	<u>231,088</u>	<u>231,088</u>	<u>1,825,980</u>	790.17%
TOTAL REVENUE & OTHER RESOURCES	<u>\$ 11,522,550</u>	<u>\$ 11,522,550</u>	<u>\$ 4,750,527</u>	41.23%
 <b>EXPENDITURES BY FUNCTION:</b>				
INSTRUCTIONAL	\$ 8,028,656	\$ 7,784,081	\$ 2,902,905	37.29%
STUDENT SERVICES	2,005,061	1,952,491	1,167,792	59.81%
GENERAL INSTITUTIONAL	1,369,381	1,349,381	388,217	28.77%
PHYSICAL PLANT	14,647	-	450	0.00%
PUBLIC SERVICE	<u>420,941</u>	<u>420,941</u>	<u>223,936</u>	53.20%
TOTAL EXPENDITURES	<u>\$ 11,838,686</u>	<u>\$ 11,506,894</u>	<u>\$ 4,683,300</u>	40.70%

**GATEWAY TECHNICAL COLLEGE**  
**2024-25 SUMMARY OF REVENUE & EXPENDITURES AS OF 01/31/2025**

<b><u>SPECIAL REVENUE-NON AIDABLE FUND</u></b>	<b>2024-25 APPROVED BUDGET</b>	<b>2024-25 WORKING BUDGET</b>	<b>2024-25 ACTUAL TO DATE</b>	<b>PERCENT INCURRED</b>
<b>REVENUE:</b>				
STATE AIDS	\$ 2,273,600	\$ 2,273,600	\$ 1,008,589	44.36%
OTHER STUDENT FEES	901,713	901,713	1,000,506	110.96%
INSTITUTIONAL	2,128,650	2,128,650	1,372,424	64.47%
FEDERAL	<u>20,079,068</u>	<u>20,079,068</u>	<u>11,269,333</u>	56.12%
<b>TOTAL REVENUE &amp; OTHER RESOURCES</b>	<b><u>\$ 25,383,031</u></b>	<b><u>\$ 25,383,031</u></b>	<b><u>\$ 14,650,852</u></b>	<b>57.72%</b>
 <b>EXPENDITURES BY FUNCTION:</b>				
STUDENT SERVICES	\$ 25,976,031	\$ 25,976,031	\$ 14,664,840	56.46%
GENERAL INSTITUTIONAL	<u>7,000</u>	<u>7,000</u>	<u>8,954</u>	127.92%
<b>TOTAL EXPENDITURES</b>	<b><u>\$ 25,983,031</u></b>	<b><u>\$ 25,983,031</u></b>	<b><u>\$ 14,673,794</u></b>	<b>56.47%</b>



**GATEWAY TECHNICAL COLLEGE**  
**2024-25 SUMMARY OF REVENUE & EXPENDITURES AS OF 01/31/2025**

<u><b>CAPITAL PROJECTS FUND</b></u>	<b>2024-25 APPROVED BUDGET</b>	<b>2024-25 WORKING BUDGET</b>	<b>2024-25 ACTUAL TO DATE</b>	<b>PERCENT INCURRED</b>
<b>REVENUE:</b>				
STATE AIDS	\$ 1,260,000	\$ 1,260,000	\$ 28,776	2.28%
INSTITUTIONAL	360,622	360,622	265,599	73.65%
FEDERAL	111,000	111,000		0.00%
OTHER RESOURCES	<u>12,000,000</u>	<u>12,000,000</u>	<u>10,156,979</u>	84.64%
<b>TOTAL REVENUE &amp; OTHER RESOURCES</b>	<u><u>\$ 13,731,622</u></u>	<u><u>\$ 13,731,622</u></u>	<u><u>\$ 10,451,355</u></u>	76.11%
 <b>EXPENDITURES BY FUNCTION:</b>				
INSTRUCTIONAL	\$ 4,121,000	\$ 4,085,000	\$ 2,146,693	52.55%
INSTRUCTIONAL - RESOURCES	20,000	20,000	-	0.00%
STUDENT SERVICES	70,000	70,000	-	0.00%
GENERAL INSTITUTIONAL	2,425,000	2,425,000	1,815,042	74.85%
PHYSICAL PLANT	7,060,622	7,050,000	3,946,711	55.98%
PUBLIC SERVICE	<u>35,000</u>	<u>35,000</u>	<u>-</u>	0.00%
<b>TOTAL EXPENDITURES</b>	<u><u>\$ 13,731,622</u></u>	<u><u>\$ 13,685,000</u></u>	<u><u>\$ 7,908,446</u></u>	57.79%

**GATEWAY TECHNICAL COLLEGE**  
**2024-25 SUMMARY OF REVENUE & EXPENDITURES AS OF 01/31/2025**

<u><b>DEBT SERVICE FUND</b></u>	<b>2024-25 APPROVED BUDGET</b>	<b>2024-25 WORKING BUDGET</b>	<b>2024-25 ACTUAL TO DATE</b>	<b>PERCENT INCURRED</b>
<b>REVENUE:</b>				
LOCAL GOVERNMENT	\$ 17,103,000	\$ 17,103,000	\$ 17,103,000	100.00%
INSTITUTIONAL	100,000	100,000	90,063	90.06%
OTHER RESOURCES	<u>373,290</u>	<u>373,290</u>	<u>401,541</u>	107.57%
TOTAL REVENUE & OTHER RESOURCES	<u>\$ 17,576,290</u>	<u>\$ 17,576,290</u>	<u>\$ 17,594,603</u>	100.10%
<b>EXPENDITURES BY FUNCTION:</b>				
PHYSICAL PLANT	<u>\$ 17,391,290</u>	<u>\$ 17,391,290</u>	<u>\$ 2,150,676</u>	12.37%
TOTAL EXPENDITURES	<u>\$ 17,391,290</u>	<u>\$ 17,391,290</u>	<u>\$ 2,150,676</u>	12.37%

**GATEWAY TECHNICAL COLLEGE**  
**2024-25 SUMMARY OF REVENUE & EXPENDITURES AS OF 01/31/2025**

<u><b>ENTERPRISE FUND</b></u>	<b>2024-25 APPROVED BUDGET</b>	<b>2024-25 WORKING BUDGET</b>	<b>2024-25 ACTUAL TO DATE</b>	<b>PERCENT INCURRED</b>
<b>REVENUE:</b>				
LOCAL GOVERNMENT	\$ 45,000	\$ 45,000	\$ 45,000	100.00%
OTHER STUDENT FEES	208,500	208,500	100,396	48.15%
INSTITUTIONAL	<u>446,500</u>	<u>446,500</u>	<u>280,334</u>	62.78%
TOTAL REVENUE & OTHER RESOURCES	<u>\$ 700,000</u>	<u>\$ 700,000</u>	<u>\$ 425,729</u>	60.82%
 <b>EXPENDITURES BY FUNCTION:</b>				
AUXILIARY SERVICES	<u>\$ 700,000</u>	<u>\$ 700,000</u>	<u>\$ 454,549</u>	64.94%
TOTAL EXPENDITURES	<u>\$ 700,000</u>	<u>\$ 700,000</u>	<u>\$ 454,549</u>	64.94%

# GATEWAY TECHNICAL COLLEGE DISTRICT BOARD

Roll Call  
Action X  
Information  
Discussion

## CASH AND INVESTMENT SCHEDULES

**Summary of Item:** Monthly cash and investment schedules

Ends Statements and/or Executive Limitations:  
Section 3 - Executive Limitations  
Policy 3.5 Financial Condition

**Staff Liaison:** Sharon Johnson

**GATEWAY TECHNICAL COLLEGE**  
**MONTHLY CASH RECONCILIATION**  
**FOR THE MONTH ENDING DECEMBER 31, 2024**

**Cash Balance: NOVEMBER 30, 2024** \$ 34,591,069.10

**PLUS:**

Cash Receipts 778,279.77

\$ 35,369,348.87

**LESS:**

Disbursement:

Payroll 4,467,488.14

Accounts Payable 4,191,143.06 8,658,631.20

**Cash Balance: DECEMBER 31, 2024** \$ 26,710,717.67

**DISPOSITION OF FUNDS**

Cash in Bank 1,421,223.13

Cash in Transit 21,677.03

Investments 25,262,492.51

Cash on Hand 5,325.00

**Cash Balance: DECEMBER 31, 2024** \$ 26,710,717.67

GATEWAY TECHNICAL COLLEGE  
MONTHLY INVESTMENT REPORT

JULY 2024 - JUNE 2025

	Investments at Beginning of Month	Investments at End of Month	Change in Investments for Month	Investments Income for Month	YTD Investments Income	Average Monthly Rate of Investment Income
July-24	\$ 50,687,502	\$ 40,637,155	\$(10,050,347)	\$ 174,437	\$ 174,437	4.45
AUGUST	40,637,155	50,808,195	10,171,040	174,608	349,045	4.35
SEPTEMBER	50,808,195	43,730,896	(7,077,299)	167,527	516,572	4.15
OCTOBER	43,730,896	43,200,904	(529,992)	153,586	670,158	4.09
NOVEMBER	43,200,904	34,459,456	(8,741,448)	128,436	798,594	4.10
DECEMBER	34,459,456	25,262,493	(9,196,963)	106,102	904,696	4.08
January-25			-		904,696	
FEBRUARY			-		904,696	
MARCH			-		904,696	
APRIL			-		904,696	
MAY			-		904,696	
JUNE			-		904,696	

**INVESTMENT SCHEDULE**

**December 31, 2024**

<b><u>NAME OF BANK/INST</u></b>	<b><u>DATE INVESTED</u></b>	<b><u>DATE OF MATURITY</u></b>	<b><u>AMOUNT</u></b>	<b><u>INTEREST RATE</u></b>	<b><u>PRESENT STATUS</u></b>
LOCAL GOV'T POOL	Various	Open	\$ 9,764,354	4.61	OPEN
JOHNSON BANK	Various	Open	\$ 15,498,139	3.75	OPEN
		TOTAL	<u>\$ 25,262,493</u>		

# GATEWAY TECHNICAL COLLEGE DISTRICT BOARD

Roll Call	_____
Action	_____ X _____
Information	_____
Discussion	_____

## PERSONNEL REPORT

Summary of Item: Monthly Personnel Activity Report

- Employment Approvals: New Hire(s)
- Retirement(s)

Ends Statements and/or Executive Limitations:

Section 3: Executive Limitations

Policy 3.3 – Employment, Compensation & Benefits

Staff Liaison: Jacqueline Morris

# Personnel Report



## February 2025

### **Employment Approvals: New Hires**

Gahdius Jones

Instructor, CDL; School of Business & Transportation; Kenosha; Annual Salary: \$70,000  
Effective: January 6, 2025

Taylor Espeseth

Instructor, Nursing Assistant; School of Health; Racine; Annual Salary: \$74,087 Effective:  
January 6, 2025

Jennifer Busch

Academic Advisor; Student Affairs; Kenosha; Annual Salary: \$70,000 Effective: January  
14, 2025

Sahan Jayasuriya

Marketing Communications Specialist; Community & Government Relations; Kenosha;  
Annual Salary: \$64,480 Effective: January 13, 2025

### **Retirement(s)**

Dawn Hermann

Financial Specialist; Kenosha; Effective: January 24, 2025

Terry Simmons

Dean, School of PaHS; Burlington; Effective: January 3, 2025

Anthony Boothe

Custodian; Kenosha; Effective: January 3, 2025

Mary Goodhall

Learning Success Coach, Nursing; Kenosha; Effective: January 31, 2025

# GATEWAY TECHNICAL COLLEGE DISTRICT BOARD

Roll Call	_____
Action	<u>  X  </u>
Information	_____
Discussion	_____

## CONTRACTS FOR INSTRUCTIONAL DELIVERY

Summary of Items:     **1. 38.14 Contract reports for February 2025**  
lists all contracts for service completed or  
in progress 2024/2025 fiscal year.

Ends Statements and/or Executive Limitations:  
Policy 4.4 College Strategic Directions/Ends Statements #1 and #3

Staff Liaison:             Mark Kappes

# BWS CFS Board Report FY25



Estimated Revenue" YTD: \$1,109,795.12

Contract #	Sponsor Name	Course Numbers	Grant Type / No.	CFS Date	Estimated CFS Revenue	
1	0001	Racine Youthful Offenders Correctional Facility (RYOCF)	664-110-1ZBR, 628-109-1ZBR, 664-105-1ZBR, 664-118-1ZBR, 664-103-1ZBR		02/29/24	\$45,270.00
2	0002	Racine Youthful Offenders Correctional Facility (RYOCF)	804-370-1ZBR		03/06/24	\$8,565.00
3	0003	Racine Correctional Institution (RCI)	449-403-1ZBR, 475-400-1ZBR		03/18/24	\$18,489.00
4	0004	Primex Family of Companies	103-833-1ZBP		03/14/24	\$1,792.00
5	0005	Kenosha Correctional Center (KCC)	444-339-1CBK, 444-337-1CBK, 444-316-1CBK, 444-331-1CBK, 804-370-1CBK, 449-403-1CBK, 103-804-1CBK, 444-406-1CBK		03/22/24	\$73,012.00
6	0006	Racine Correctional Institution (RCI)	444-331-1ZBR, 444-339-1ZBR, 444-316-1ZBR, 449-403-1ZBR, 444-406-1ZBR		03/28/24	\$49,294.00
7	0007	Modine Manufacturing Company, Inc.	103-840-1ZBA, 103-839-1ZBA, 103-844-1ZBA		04/08/24	\$3,136.00
8	0008	Robert E. Ellsworth Correctional Center (REECC)	444-331-1CBE, 444-337-1CBE, 444-339-1CBE, 444-316-1CBE, 804-370-1CBE, 801-302-1CBE, 103-804-1CBE, 900-019-1CBE		04/10/24	\$78,210.00
9	0009	Eaton	196-413-1ZBA, 196-413-1ZBB		04/09/24	\$5,765.72
10	0010	Puratos	196-850-1ZBP		04/09/24	\$2,897.40
11	0011	Andes Candies	620-497-1ZBA; 900-003-1M1AC	181	05/02/24	\$1,935.00
12	0012	KABA	196-848-1ZBK		05/07/24	\$1,737.84
13	0013	WE Energies	420-408-1CBW		05/08/24	\$21,760.00
14	0014	KABA	196-849-2ZBK, 196-850-2ZBK		05/09/24	\$3,475.68
15	0015	Eaton Corporation	196-413-1ZBC, 196-413-1ZBD		05/31/24	\$6,122.48
16	0016	Continental Plastics	620-459-1ZBA		07/02/24	\$2,840.00
17	0017	WRTP / Big Step	607-104-1CMA		06/03/24	\$8,535.00
18	0018	Thermal Transfer Products	196-419-1ZBA, 196-419-1ZBB; 900-003-1M1TT	182	06/04/24	\$2,419.00
19	0019	Andes Candies LLC	628-412-1EBA; 900-003-1M1AD	181	06/05/24	\$2,419.00
20	0020	Bothe Associates	620-405-1CBA		06/05/24	\$4,032.00
21	0021	WCEDA	196-850-1EBA		06/05/24	\$1,830.32
22	0022	Scot Forge Company	420-475-1EBS, 420-446-1EBS, 444-453-1EBS, 420-476-1EBS, 420-477-1EBS		06/11/24	\$35,297.55
23	0023	Amorim Cork Composites	103-845-1ZBA		06/12/24	\$2,332.46
24	0024	Great Northern Corporation	612-409-1ZBG; 900-003-1M1GN	179	06/14/24	\$672.00
25	0026	Great Northern Corporation	196-828-1ZBG, 196-828-1ZBH, 900-019-1ZBG; 900-003-1M1GW	179	06/21/24	\$3,986.00
26	0027	InSinkErator	628-415-1CBA		07/08/24	\$4,983.97
27	0028	Twin Disc	612-419-1ZBD, 612-419-1ZBE; 900-003-1M1TW	176	07/12/24	\$1,290.00
28	0030	Plas-Tech Engineering	420-434-1ZBA, 420-434-1ZBB		07/15/24	\$5,696.40
29	0031	Racine Youthful Offenders Correctional Facility (RYOCF)	804-370-1ZBA		07/16/24	\$11,540.00
30	0032	Racine Youthful Offenders Correctional Facility (RYOCF)	620-108-2ZBR, 612-102-2ZBR, 664-110-2ZBR, 628-109-2ZBR, 664-105-2ZBR, 664-118-2ZBR, 664-103-2ZBR		07/16/24	\$69,310.00
31	0033	Nestle USA, Inc.	900-019-1ZBN		07/19/24	\$906.00
32	0034	Radius Packaging	900-019-1ZBA		07/24/24	\$7,659.20
33	0035	Yaskawa America, Inc.	420-446-1ZBA		07/26/24	\$1,825.50
34	0036	Burlington High School	531-448-1ZBB		08/02/24	\$1,627.94
35	0037	Burlington High School	531-448-2ZBB		08/02/24	\$1,627.94
36	0038	Thermal Transfer Products	420-481-1CBA, 420-481-1CBB; 900-003-1M1TP	182	08/06/24	\$4,838.00

	Contract #	Sponsor Name	Course Numbers	Grant Type / No.	CFS Date	Estimated CFS Revenue
37	0039	Filtration Group	620-458-2ZBA; 900-003-2M1FG	185	08/05/24	\$2,016.00
38	0040	Amorim Cork Composites	103-845-2ZBA		08/06/24	\$2,332.46
39	0041	Kerry Ingredients	620-422-1CBA		08/13/24	\$6,138.06
40	0042	Kerry Ingredients	620-421-2CBA, 900-019-2CBA		08/13/24	\$6,272.00
41	0043	WRTP / Big Step	607-104-2CBA		08/21/24	\$8,535.00
42	0044	Twin Disc	623-825-1ZBA, 623-825-1ZBB; 900-003-1M1TI	176	08/21/24	\$806.00
43	0045	Walworth County Jail	890-721-2ZBA, 859-777-2ZBA, 858-733-2ZBA, 854-733-2ZBA, 856-740-2ZBA, 859-798-2ZBA		08/22/24	\$7,455.00
44	0046	Continental Plastic	620-460-2ZBA, 900-019-2ZBA		08/23/24	\$2,240.00
45	0047	Primex Family of Companies	531-892-2ZBA		09/09/24	\$3,106.50
46	0048	WCEDA	196-848-2EBA		09/16/24	\$1,830.32
47	0049	Royal Basket Trucks	861-714-2ZBA, 861-723-2ZBA; 900-003-2M1RB	187	09/16/24	\$3,763.00
48	0050	HFI Fluid Power	420-475-2CBA, 420-475-2CBB; 900-003-2M1HF	186	09/23/24	\$4,838.00
49	0052	Walworth County	531-817-1ZBA		09/26/24	\$1,048.48
50	0053	Walworth County	531-448-2ZBA		10/01/24	\$3,053.57
51	0055	Amorim Cork Composites	103-833-2ZBA, 103-833-2ZBB, 103-839-2ZBA, 103-839-2ZBB		10/04/24	\$6,008.92
52	0056	Scot Forge Company	420-475-2EBS, 420-446-2EBS, 444-453-2EBS, 420-482-2EBS, 420-483-2EBS		10/11/24	\$35,033.97
53	0057	Kerry Ingredients	620-404-2CBA		10/18/24	\$4,032.00
54	0058	WCEDA	196-848-2EBB		10/22/24	\$1,830.32
55	0059	Soaris, LLC	620-458-2ZBS, 196-422-2ZBS; 900-003-2M1SL	189	10/29/24	\$2,016.00
56	0060	Avidity Science	620-440-2CBA; 900-003-2M1AS	184	10/22/24	\$1,344.00
57	0061	Kenosha Correctional Center (KCC)	444-339-3CBK, 444-337-3CBK, 444-316-3CBK, 444-331-3CBK, 804-370-3CBK, 449-403-3CBK, 103-804-3CBK, 444-406-3CBK		10/29/24	\$73,012.00
58	0062	Amorim Cork Composites	103-844-2ZBB		10/30/24	\$702.82
59	0063	Racine Correctional Institution (RCI)	444-339-3ZBR, 444-337-3ZBR, 444-331-3ZBR, 444-316-3ZBR, 804-370-3ZBR, 449-403-3ZBR, 444-406-3ZBR		10/31/24	\$75,280.00
60	0064	Racine Youthful Offenders Correctional Facility (RYOCF)	804-370-3ZBA		10/31/24	\$10,275.00
61	0065	Racine Youthful Offenders Correctional Facility (RYOCF)	620-108-3ZBR, 612-102-3ZBR, 664-110-3ZBR, 628-109-3ZBR, 664-105-3ZBR, 664-118-3ZBR, 664-103-3ZBR		10/31/24	\$67,375.00
62	0066	KABA	196-848-3ZBA, 196-849-3ZB, 196-850-3ZBA		11/06/24	\$5,233.68
63	0067	Robert E. Ellsworth Correctional Center (REECC)	444-331-3CBE, 444-337-3CBE, 444-339-3CBE, 444-316-3CBE, 804-370-3CBE, 801-302-3CBE, 103-804-3CBE, 900-019-3CBE		11/08/24	\$74,316.00
64	0068	Racine Unified School District (RUSD)	623-400-2ZBA		11/14/24	\$672.00
65	0069	GTC School of Pre-College & Momentum Programs	444-339-3CBW, 444-337-3CBW, 444-331-3CBW, 449-403-3CBW, 103-804-3CBW, 804-370-3CBW	226	01/08/25	\$88,356.00
66	0070	AbbVie	900-019-3ZBD		11/26/24	\$11,400.00
67	0071	Eaton Corporation	900-019-2ZBE		12/03/24	\$17,052.00
68	0072	Strohwig Industries, Inc.	420-445-2ZBA		12/06/24	\$2,404.50
69	0073	Avidity Science	107-847-2ZBA; 900-003-2M1AV	184	12/10/24	\$269.00
70	0074	Filtration Group	620-433-2ZBA; 900-003-2M1FL	185	02/03/25	\$2,016.00
71	0075	WRTP / Big Step	607-104-3CBB		12/13/24	\$8,535.00
72	0076	Caterpillar, Inc.	444-453-2ZBA		12/13/24	\$4,614.00
73	0077	Twin Disc, Inc.	900-019-3ZBT		12/16/24	\$3,800.00
74	0078	Uline, Inc.	103-406-3ZBA, 900-019-3ZBA		12/20/24	\$2,912.00
75	0079	Parker Plastics	449-403-3CBA		12/19/24	\$2,648.12
76	0080	Avidity Science	420-434-3ZBA, 420-434-3ZBB, 420-434-3ZBC, 420-449-3ZBA, 420-449-3ZBB; 900-003-3M1AV	184	01/06/25	\$4,300.00

	Contract #	Sponsor Name	Course Numbers	Grant Type / No.	CFS Date	Estimated CFS Revenue
77	0081	HFI Fluid Power	420-447-3CBH; 900-003-3M1HF	186	01/09/25	\$2,688.00
78	0082	WCEDA	196-849-3EBW, 196-850-3EBW		01/14/25	\$3,264.00
79	0083	Royal Basket Trucks	861-723-3ZBA, 861-824-3ZBA; 900-003-3M1RB	187	01/22/25	\$3,763.00
80	0084	Silgan Containers	620-458-3ZBA, 620-458-3ZBB, 620-458-3ZBC; 900-003-3M1SC	188	01/22/25	\$6,048.00
81	0085	Avidity Science	107-847-3ZBA, 103-845-3ZBA; 900-003-3M1AS	184	01/22/25	\$717.00
82	0086	Scot Forge Company	420-475-3EBS, 420-448-3EBS, 444-453-3EBS, 420-482-3EBS, 420-483-3EBS		01/23/25	\$37,312.00

# GATEWAY TECHNICAL COLLEGE DISTRICT BOARD

Roll Call	_____
Action	<u>  X  </u>
Information	_____
Discussion	_____

## CONTRACTS FOR INSTRUCTIONAL DELIVERY

Summary of Items:     **WI Statutes 38.14**  
                          **Contract Reports for January 2025**  
                          Lists all Protective Services contracts for service completed  
                          or in progress ending FY2024-25.

Ends Policy 4.1: Statement #2

Staff Liaison:           Robin Rupp

# Protective Services Board Report FY25



Estimated Revenue YTD: \$348,345.60

Contract #	Sponsor Name	Course Numbers	Grant Type / No.	CFS Date / Date Req.	Estimated CFS Revenue
1 2000	Milwaukee County Juvenile Detention Center	504-427-1K1A		05/31/24	\$500.00
2 2001	Racine Juvenile Detention	504-427-1K1B		05/31/24	\$250.00
3 2002	Beloit Police Department	504-427-1K1C		05/31/24	\$125.00
4 2003	Germantown Police Department	504-427-1K1D		05/31/24	\$125.00
5 2004	Kenosha County Sheriff's Department	504-427-1K1E		05/31/24	\$125.00
6 2005	Racine Police Department	504-427-1K1F		05/31/24	\$125.00
7 2006	Randall Police Department	504-427-1K1G MAKE PRIMARY FOR Multi Recip!		05/31/24	\$125.00
8 2007	Twin Lakes Police Department	504-427-1K1H		05/31/24	\$125.00
9 2008	Racine County Sheriff's Department	504-415-1K1A		06/21/24	\$2,400.00
10 2009	Kenosha County Sheriffs	504-415-1K1B		06/21/24	\$600.00
11 2010	Caledonia Police Department	504-415-1K1C		06/21/24	\$300.00
12 2011	UW-Parkside Police Department	504-415-1K1D		06/21/24	\$300.00
13 2013	Port Washington Police	504-415-1K1E		06/21/24	\$300.00
14 2014	Franklin Police Department	504-415-1K1F		06/21/24	\$300.00
15 2015	Walworth County Sheriffs Department	504-475-1H1A		06/21/24	\$990.00
16 2016	Genoa City Police Department	504-475-1H1B		06/21/24	\$330.00
17 2017	Delavan Police Dept	504-475-1H1C		06/21/24	\$165.00
18 2018	Walworth County Sheriffs Department	504-474-1H1A, 504-474-1H1B, 504-474-1H1C		05/03/24	\$3,075.00
19 2019	Genoa City Police Department	504-474-1H1D		05/03/24	\$225.00
20 2020	Kenosha Police Department	504-481-1K1A		05/03/24	\$400.00
21 2021	WI DOJ LESB	504-503-1K1B, 504-506-1K1B, 504-500-1K1B, 504-510-1K1B, 504-501-1K1B		05/01/24	\$73,417.52
22 2022	WI DOJ LESB	504-504-2K1B, 504-509-2K1B, 504-508-2K1B, 504-502-2K1B, 504-507-2K1B, 504-505-2K1B, 504-511-2K1B		05/01/24	\$116,582.48
23 2023	Elkhorn Police Department	504-481-1K1B		06/28/24	\$100.00
24 2024	Mount Pleasant Police Department	504-481-1K1C		06/28/24	\$50.00
25 2025	WI DOJ LESB	504-485-1Z1A		07/30/24	\$42,000.00
26 2026	LaCrosse Sherriff Department	504-485-1Z1Y		08/22/24	\$1,500.00
27 2027	Milwaukee Co Juvenile Detetion Ctr	504-485-1Z1Z		08/22/24	\$1,500.00
28 2028	Racine County Juv Det Ctr	504-485-1Z1X		08/22/24	\$1,500.00
29 2029	Racine County Sheriff	504-427-2K1A		09/02/24	\$1,000.00
30 2030	Mount Pleasant Police Department	504-427-2K1B		09/02/24	\$500.00
31 2035	Milwaukee Juvenile Detention Center	504-405-2K1A		09/08/24	\$3,500.00
32 2036	Kenosha County Sheriff's Dept	504-405-2K1B		09/08/24	\$2,625.00
33 2037	Racine County Sheriffs Department	504-405-2K1C		09/08/24	\$1,750.00
34 2038	Wauwatosa Police Department	504-405-2K1D		09/08/24	\$875.00

Contract #	Sponsor Name	Course Numbers	Grant Type / No.	CFS Date / Date Req.	Estimated CFS Revenue	
35	2039	Racine Police Department	504-416-2Z1A		09/08/24	\$2,100.00
36	2040	Beloit Police Department	504-416-2Z1B		09/08/24	\$700.00
37	2041	Franklin Police Department	504-416-2Z1C		09/08/24	\$700.00
38	2042	Racine County Sheriffs Department	504-416-2Z1D		09/08/24	\$700.00
39	2043	Mountain Bay Metropolitan Police Department	504-416-2Z1E		09/08/24	\$350.00
40	2044	Whitewater Police Department	504-475-2H1A		09/10/24	\$1,320.00
41	2045	WI DOJ LESB	504-458-2Z1A		09/10/24	\$43,700.00
42	2046	Racine County Sheriffs Department	504-480-2K1A		10/04/24	\$1,000.00
43	2047	Bayside Police Department	504-480-2K1B		10/04/24	\$250.00
44	2048	Kenosha Police Department	504-480-2K1C		10/04/24	\$250.00
45	2049	Randall Police Department	504-480-2K1D		10/04/24	\$250.00
46	2050	Beloit Police Department	504-415-2K1A		10/04/24	\$900.00
47	2051	Burlington Police Department	504-415-2K1B		10/04/24	\$600.00
48	2052	Port Washington Police Department	504-415-2K1C		10/04/24	\$600.00
49	2053	South Milwaukee Police Department	504-415-2K1D		10/04/24	\$600.00
50	2054	Brown Deer Police Department	504-415-2K1E		10/04/24	\$300.00
51	2055	Dodge County Sheriffs Department	504-415-2K1F		10/04/24	\$300.00
52	2056	Price County Sheriff's Department	504-415-2K1G		10/04/24	\$300.00
53	2057	Sharon Police Department	504-415-2K1H		10/04/24	\$300.00
54	2058	Kenosha Police Department	504-481-2K1A		10/25/24	\$450.00
55	2059	WI DOJ LES	504-502-2K12, 504-507-2K12, 504-505-2K12,504-511-2K1C		05/31/24	\$4,890.60
56	2060	Kenosha Fire Department	Hold		01/07/25	pending
57	2061	WI DOJ LESB	504-503-3K12, 504-500-3K12, 504-510-3K12, 504-506-3K12, 504-509-3K12,504-508-3K12, 504-501-3K12		01/12/25	\$12,000.00
58	2062	WI DOJ LESB	504-485-3Z1A		01/13/25	\$4,500.00
59	2063	WI DOJ LESB	504-503-3K1A, 504-500-3K1A, 504-510-3K1A, 504-506-3K1A, 504-509-3K1A, 504-504-3K1A, 504-508-3K1A, 504-507-3K1A, 504-502-3K1A, 504-505-3K1A, 504-501-3K1A		01/20/25	\$5,000.00
60	2064	Racine Sheriff's Office	504-479-3K1A		01/21/25	\$2,400.00
61	2065	Kenosha Police Department	504-479-3K1B		01/21/25	\$1,800.00
62	2066	Mount Pleasant Police Department	504-479-3K1C		01/21/25	\$1,200.00
63	2067	Lac Courte Oreilles Tribal Police Department	504-479-3K1D		01/21/25	\$600.00
64	2068	WI DOJ LESB	504-504-1K12, 504-507-1K12, 504-502-1K12,504-505-1K12, 504-505-1K112		01/13/25	\$1,000.00
65	2069	WI DOJ LESB	504-511-2K12		01/13/25	\$500.00
66	2070	WI DOJ LESB	504-511-1K1A		01/13/25	\$1,000.00



# GATEWAY TECHNICAL COLLEGE DISTRICT BOARD

Roll Call	_____
Action	<u>  X  </u>
Information	_____
Discussion	_____

## CONTRACTS FOR INSTRUCTIONAL DELIVERY

Summary of Items:     **WI Statutes 38.14**  
                          **Contract Reports for February 2025**  
                          Lists all High School contracts for service completed or in  
                          progress during FY2024-2025.

Ends Policy 4.1: Statement #5

Staff Liaison:           Katie Graf

2024-2025 Contract Log Numbers Dual Credit CFS HS

<b>Revenue Generating Contract Estimate:</b>	<b>\$1,015,753.00</b>
<b>Transcripted Credit Contract Estimate:</b>	<b>\$3,122,300.00</b>
<b>Total High School Contract Estimate:</b>	<b>\$4,138,053.00</b>

Contract #	2025-	School District	Section	Term	Contract Estimate	Invoiced Amount	Multi-Recipient Contract Participating Schools	Course Type	Academy/Grant	Notes
1001		Mukwonago High School	543-300-1ZGE, 1ZGJ, 1ZGF, 1ZGK	2024SU	\$14,000.00	\$22,077.60		HS		
1002		RUSD	543-300-1RGA, 1RGC, 1RGB, 1RGD	2024SU	\$12,000.00	\$14,077.60		HS		
1003		KUSD	543-300-1KGC & 1KGD	2024SU	\$12,000.00	\$7,038.80		HS		
1004		Career and College Academy	890-155-1EGA, 838-105-1EGA, 809-172-1EG3A, 890-155-1EGB	2024SU	\$14,000.00	\$20,565.56		HS		
1005		REAL School RUSD	890-155-1CGA, 890-155-1CGB, 890-155-1CGC, 890-155-1CGD	2024SU	\$10,000.00	\$12,050.12		HS		
1006		REAL School RUSD	444-446-1CGA, 444-446-1CGB, 444-446-1CGC, 444-446-1CGD, 605-465-1CGA, 605-465-1CGB	2024SU	\$6,000.00	\$33,096.00		HS		
1007		Multi-Recipient	543-300-1ZGG	2024SU	\$6,000.00	\$12,038.80	Greenfield, Franklin, St Francis, Greendale	HS		
1008		Westosha Central High School	Transcripted Credit	2024SU	\$25,000.00	\$25,457.16		TCCF		
1009		Multi-Recipient	442-330-2EGA, 442-332-2EGA	2024FA	\$5,000.00	\$9,910.74	Burlington, CCA, Elkhorn, Union Grove, Wilmot	HS	Advanced Welding-Elkhorn	
1010		Multi-Recipient	442-330-2RGA, 442-332-2RGA	2024FA	\$5,000.00	\$2,831.64	Union Grove, Westosha	HS	Advanced Welding-Racine	
1011		Multi-Recipient	442-333-3EGA, 457-336-3EGA	2025SP	\$5,000.00		Burlington, CCA, Elkhorn, Union Grove, Wilmot	HS	Advanced Welding-Elkhorn	
1012		Multi-Recipient	442-333-3RGA, 457-336-3RGA	2025SP	\$5,000.00		Union Grove, Westosha	HS	Advanced Welding-Racine	
1013		Multi-Recipient	402-136-2HGA	2024FA	\$3,000.00	\$6,472.44	Burlington, Racine Lutheran, Waterford, Wilmot	HS	Aviation	
1014		Multi-Recipient	402-129-3HGA	2025SP	\$3,000.00		Burlington, Racine Lutheran, Waterford, Westosha, Wilmot	HS	Aviation	
1015		Multi-Recipient	444-331-2EGA, 444-337-2EGA	2024FA	\$6,000.00	\$13,099.02	Burlington, CCA, Elkhorn, Options, Union Grove	HS	CNC	
1016		Multi-Recipient	444-316-3EGA, 444-339-3EGA	2025SP	\$6,000.00		Burlington, CCA, Elkhorn, Options, Union Grove	HS	CNC	
1017		Multi-Recipient	504-900-2EGA, 504-903-2EGA	2024FA	\$3,000.00	\$8,485.72	Burlington, CCA, Elkhorn, Waterford, Westosha	HS	Criminal Justice-Elkhorn	
1018		Multi-Recipient	504-900-3RGA, 504-903-2RGA	2024FA	\$3,000.00	\$6,988.24	Saint Catherine's, Union Grove, Waterford, Horlick	HS	Criminal Justice-Racine	
1019		Multi-Recipient	504-174-3EGA, 504-905-3EGA	2025SP	\$3,000.00		Burlington, CCA, Elkhorn, Waterford, Westosha	HS	Criminal Justice-Elkhorn	

2024-2025 Contract Log Numbers Dual Credit CFS HS

1020	Multi-Recipient	504-174-3RGA, 504-905-3RGA	2025SP	\$3,000.00		Saint Catherine's, Union Grove, Waterford, Horlick	HS	Criminal Justice-Racine
1021	Multi-Recipient	531-312-2BGA, 531-313-2BGA	2024FA	\$7,000.00	\$7,155.33	Burlington, Elkhorn, Westosha, Williams Bay	HS	Fire/EMS
1022	Multi-Recipient	503-302-2ZGA, 531-312-2ZGA	2024FA	\$7,000.00	\$9,540.44	Burlington, Elkhorn, Westosha, Williams Bay	HS	Fire/EMS
1023	Multi-Recipient	503-302-2BGA, 503-307-3BGA	2025SP	\$7,000.00		Case, Saint Catherine's, Walden III, Horlick, Park	HS	Fire/EMS
1024	Multi-Recipient	503-307-3ZGA, 531-313-3ZGA	2025SP	\$7,000.00		Case, Saint Catherine's, Walden III, Horlick, Park	HS	Fire/EMS
1025	Multi-Recipient	601-110-3EGA, 601-116-3EGA, 601-304-3EGA	2025SP	\$4,000.00		Burlington, Elkhorn	HS	HVAC
1026	Multi-Recipient	806-177-2EGA	2024FA	\$5,000.00	\$6,064.92	Catholic Central, DDHS, East Troy, Elkhorn, Options, Waterford, Westosha, Williams Bay, Wilmot	HS	Nursing
1027	Multi-Recipient	806-177-2RGA	2024FA	\$5,000.00	\$6,064.92	KTEC, Racine Lutheran, Saint Catherine's, Horlick, Waterford	HS	Nursing
1028	Multi-Recipient	543-102-3EGA, 809-188-3WGA	2025SP	\$6,000.00		Catholic Central, DDHS, Elkhorn, Options, Waterford, Westosha, Williams Bay, Wilmot	HS	Nursing
1029	Multi-Recipient	543-102-3RGA, 809-188-3RGA	2025SP	\$6,000.00		KTEC, Racine Lutheran, Saint Catherine's, Horlick	HS	Nursing
1030	Multi-Recipient	801-198-2WGA, 809-188-2WGA	2024FA	\$6,000.00	\$10,981.52	Big Foot, Elkhorn, KTEC, Saint Catherine's, Union Grove, Williams Bay	HS	LA&S
1031	Multi-Recipient	801-198-2EGA, 809-188-2EGA	2024FA	\$6,000.00	\$10,981.52	Big Foot, Burlington, Elkhorn, Waterford, Westosha, Union Grove	HS	LA&S
1032	Multi-Recipient	806-203-2WGA, 809-172-2WGA	2024FA	\$6,000.00	\$2,233.04	Elkhorn, Waterford, Westosha	HS	LA&S
1033	Multi-Recipient	802-220-3WGA, 809-196-3EGA	2025SP	\$6,000.00		Big Foot, Elkhorn, KTEC, Saint Catherine's, Union Grove, Williams Bay	HS	LA&S
1034	Multi-Recipient	809-166-3WGA, 809-195-3WGA	2025SP	\$6,000.00		Elkhorn, Waterford, Westosha	HS	LA&S
1035	Multi-Recipient	809-172-3EGA, 809-196-3EGA	2025SP	\$6,000.00		Big Foot, Burlington, Elkhorn, Waterford, Westosha, Union Grove	HS	LA&S
1036	Multi-Recipient	664-100-2CGA, 664-110-2CGA	2024FA	\$6,000.00	\$9,166.56	Harborside, KTEC, Saint Catherine's, Reuther	HS	SMART
1037	Multi-Recipient	664-105-3CGA, 664-120-3CGA	2025SP	\$6,000.00		Harborside, KTEC, Saint Catherine's, Reuther	HS	SMART
1038	Union Grove High School	543-300-1KGA, 543-300-	2024SU	\$3,000.00	\$7,038.80		HS	
1039	Brookfield East High School	543-300-2ZGW & 2ZGX, 900-003-2HELM	2024FA	\$6,000.00	\$13,038.80		HS	
1040	Burlington High School	501-101-2WGA	2024FA	\$0.00	\$0.00	Burlington, Big Foot	VAN	
1041	Badger High School	501-101-2WCB	2024FA	\$3,000.00	\$9,983.20		VAN	
1042	Multi-Recipient	533-126-2WCA	2024FA	\$3,000.00	\$9,029.88	Badger, Big Foot, Burlington, Elkhorn, Westosha Central, Williams Bay	VAN	
1043	Multi-Recipient	533-126-2WCB	2024FA	\$3,000.00	\$8,026.56	Burlington, Williams Bay, Big Foot	VAN	
1044	Multi-Recipient	533-126-2WCD	2024FA	\$3,000.00	\$9,698.76	Big Foot, Elkhorn, Williams Bay, Iowa Grant	VAN	
1045	Multi-Recipient	533-126-2WCF	2024FA	\$3,000.00	\$2,675.52	Big Foot, Elkhorn, Williams Bay	VAN	
1046	Multi-Recipient	533-128-2WCA	2024FA	\$3,000.00	\$4,013.28	Burlington, Whitewater, Williams Bay	VAN	
1047	Multi-Recipient	533-128-2WCB	2024FA	\$3,000.00	\$2,675.52	Badger, Big Foot, Westosha Central, Whitewater, Williams Bay	VAN	

2024-2025 Contract Log Numbers Dual Credit CFS HS

1048	Union Grove High School	809-196-2WCA, 809-198-2WCA	2024FA	\$10,000.00	\$23,460.52	Union Grove	VAN		
1049	Multi-Recipient	890-155-2WCA	2024FA	<del>\$3,000.00</del>		<del>Burlington, Elkhorn, &amp; Whitewater</del>	<del>VAN</del>		
1050	Multi-Recipient	533-127-3WCA	2025SP	\$3,000.00		Badger, Burlington, Elkhorn, Westosha Central, Williams Bay	VAN		
1051	Multi-Recipient	533-127-3WCB, 533-127-3WCE	2025SP	\$6,000.00		Burlington, Williams Bay	VAN		
1052	Multi-Recipient	533-127-3WCC, 533-127-3WCF	2025SP	\$6,000.00		Elkhorn, Williams Bay	VAN		
1053	Multi-Recipient	533-127-3WCD	2025SP	\$3,000.00		Whitewater, Williams Bay	VAN		
1054	Multi-Recipient	533-129-3WCA	2025SP	\$3,000.00		Badger, Burlington, Whitewater, Williams Bay	VAN		
1055	Multi-Recipient	533-129-3WCB	2025SP	\$3,000.00		Badger, Whitewater, Williams Bay	VAN		
1056	Badger High School	501-101-3WCA	2025SP	<del>\$0.00</del>	<del>\$0.00</del>	<del>Badger</del>	<del>VAN</del>		
1057	Union Grove High School	809-198-3WCA, 809-196-3WCA	2025SP	\$10,000.00		Union Grove	VAN		
1058	Burlington High School	442-321-2ZGA, 442-322-2ZGA, 457-309-2ZGA	2024FA	\$10,000.00	\$22,743.12		HS	Burlington Welding	
1059	Multi-Recipient	442-330-2RGB, 442-332-2RGB	2024FA	\$10,000.00	\$7,079.10	Elkhorn, KTEC, Union Grove, Westosha, Wilmot	HS	ADV. Welding	
1060	Multi-Recipient	442-333-3RGB, 457-336-3RGB	2025SP	\$10,000.00		Elkhorn, Union Grove, Westosha, Wilmot	HS	ADV. Welding	
1061	Multi-Recipient	442-321-2EGA, 442-322-2EGA, <del>442-324-2EGA,</del> 442-324-2EGB	2024FA	\$15,000.00	\$15,102.08	CCA, Elkhorn, Big Foot, <del>Westosha</del>	HS	Welding	Elkhorn
1062	Multi-Recipient	442-321-2EGB, 442-322-2EGB, 442-324-2EGA	2024FA	\$10,000.00	\$28,316.40	Elkhorn, Big Foot, CCA, Catholic Central, Westosha	HS	Welding	Elkhorn
1063	Multi-Recipient	<del>442-324-2EGB</del>	2024FA	<del>\$0.00</del>	<del>\$0.00</del>	<del>Elkhorn, Big Foot, CCA, Catholic Central, Westosha</del>	<del>HS</del>	<del>Welding</del>	<del>Elkhorn</del>
1064	Multi-Recipient	442-321-2RGA	2024FA	<del>\$0.00</del>	<del>\$0.00</del>	<del>Burlington, Racine Lutheran, St Catherines, Union Grove CCA, Elkhorn, Westosha, Williams Bay</del>	<del>HS</del>	<del>Welding</del>	<del>Racine</del>
1065	Multi-Recipient	442-321-2RGA, 442-322-2RGA, 442-324-2RGA	2024FA	\$4,000.00	\$30,204.16	Burlington, Racine Lutheran, Saint Catherine's, Union Grove	HS	Welding	Racine
1066	Multi-Recipient	442-321-2RGB, 442-322-2RGA, 442-324-2RGA	2024FA	\$10,000.00	\$11,326.56	Academy of Excellence, KTEC, Horlick, Westosha Central	HS	Welding	Racine
1067	Multi-Recipient	442-323-3EGA, 442-334-3EGA, 457-309-3EGA	2025SP	\$10,000.00		CCA, Elkhorn, Westosha, Williams Bay	HS	Welding	Elkhorn
1068	Multi-Recipient	442-323-3EGB	2025SP	\$4,000.00		Elkhorn, Big Foot, CCA, Catholic Central	HS	Welding	Elkhorn
1069	Multi-Recipient	442-334-3EGB, 457-309-3EGB	2025SP	\$8,000.00		Elkhorn, Big Foot, CCA, Catholic Central, Westosha	HS	Welding	Elkhorn
1070	Multi-Recipient	442-323-3RGA, 442-334-3RGA, 457-309-3RGA	2025SP	\$10,000.00		Burlington, Racine Lutheran, Saint Catherine's, Union Grove	HS	Welding	Racine
1071	Multi-Recipient	442-323-3RGB, 442-334-3RGB, 457-309-3RGB	2025SP	\$10,000.00		Burlington, East Troy, Elkhorn, KTEC, Westosha, Horlick	HS	Welding	Racine

2024-2025 Contract Log Numbers Dual Credit CFS HS

1072	Career and College Academy	Transcribed Credit	2024SU	\$2,000.00	\$1,996.64		TCCF		
1073	Career and College Academy	504-900-2EGB, 831-103-2EGA, 831-103-2EGB, 806-114-2EGA, 806-114-2EGB, 834-109-2EGA, 834-109-2EGB, 804-115-2EGA	2024FA	\$10,000.00	\$74,564.84		HS		Edge
1074	South Milwaukee High School	543-300-2ZGD, 543-300-2ZGL, 900-003-2HSMW	2024FA	\$3,000.00	\$13,038.80		HS		
1075	Wilmot High School	543-300-2ZGB	2024FA	\$3,000.00	\$3,519.40		HS		
1076	Oak Creek High School	543-300-2ZGM & 2ZGP, 900-003-2HOCH	2024FA	\$6,000.00	\$13,038.80		HS		
1077	Muskego High School	543-300-2ZGA, 543-300-2ZGO, 900-003-2HMUS	2024FA	\$3,000.00	\$13,038.80		HS		
1078	East Troy High School	543-300-2ZGC	2024FA	\$3,000.00	\$3,519.40		HS		
1079	Burlington High School	543-300-2ZGH	2024FA	\$3,000.00	\$3,519.40		HS		
1080	Waterford Union High School	543-300-2ZGI	2024FA	\$3,000.00	\$3,519.40		HS		
1081	Whitewater High School	543-300-2ZGR	2024FA	\$3,000.00	\$3,519.40		HS		
1082	Christian Life High School	145-119-2EGA	2024FA	\$3,000.00	\$8,984.88		HS		
1083	Ktech High School	834-109-2KGA, 834-109-2KGB, 804-135-2KGA	2024FA	\$15,000.00	\$26,455.48		HS		
1084	Ktech High School	834-109-3KGA, 801-136-3WGA, 809-198-3EGA	2025SP	\$10,000.00			HS		
1085	Lakeview Technology Academy	152-124-2LGA, 152-081-2LGA, 152-101-2LGA, 152-080-2LGA, 152-126-2LGA, 152-084-2LGA	2024FA	\$30,000.00	\$37,566.72		HS		
1086	Lakeview Technology Academy	444-337-2LGA, 444-337-2LGB, 444-316-2LGA, 444-339-2LGA, 444-339-2LGB	2024FA	\$30,000.00	\$32,152.14		HS		
1087	Lakeview Technology Academy	664-120-2LGA, 664-105-2LGA, 664-110-2LGA	2024FA	\$12,000.00	\$21,770.58		HS	Grant	

2024-2025 Contract Log Numbers Dual Credit CFS HS

		664-100-2CGB, 664-110-2CGB, 444-337-2CGA, 605-113-2CGA, 605-130-2CGA, 664-100-2CGC, 664-110-2CGC, 444-339-2CGA, 605-130-2CGB, 605-113-2CGB, 607-170-2CGA, 607-141-2CGA, 607-170-2CGB, 607-141-2CGB							
1088	REAL School RUSD		2024FA	\$55,000.00	\$82,886.35			HS	
1089	Catholic Central High School	Transcripted Credit	2024SU	\$10,000.00	\$9,484.04			TCCF	
		442-321-2ZGB, 442-332-2ZGB, 442-322-2ZGB, 442-330-2ZGB, 457-309-2ZGB, 457-336-2ZGB							
1090	Waterford Union High School		2024FA	\$30,000.00	\$22,743.12			HS	
1091	Christian Life High School	Transcripted Credit	2024SU	\$22,000.00				TCCF	Year Long
1092	Christian Life High School	Transcripted Credit	2024SU	\$5,000.00	\$8,485.72			TCCF	
1093	St. Catherine's High School	Transcripted Credit	2024SU	\$10,000.00	\$10,981.52			TCCF	
1094	St. Catherine's High School	Transcripted Credit	2024FA	\$10,000.00	\$2,495.80			TCCF	
1095	Union Grove High School	Transcripted Credit	2024FA	\$76,000.00	\$196,801.92			TCCF	
1096	Case High School RUSD	504-900-2ZGA, 504-900-2ZGB	2024FA	\$10,000.00	\$14,974.80			HS	
1097	Case High School RUSD	504-900-3ZGA, 504-900-3ZGB	2025FA	\$10,000.00				HS	
1098	Career and College Academy	502-324-2EGA, 502-301-2EGA	2024FA	\$5,000.00	\$6,169.92			HS	
1099	Career and College Academy	502-312-3EGA, 502-349-3EGA	2025SP	\$5,000.00				HS	
1100	Case High School RUSD	Transcripted Credit	2024FA	\$64,000.00				TCCF	Year Long
1101	Case High School RUSD	Transcripted Credit	2024FA	\$90,000.00	\$171,301.88			TCCF	
1102	Multi-Recipient	533-126-2WCC	2024FA	\$3,000.00	\$4,013.28	Big Foot, Elkhorn, Williams Bay		VAN	
1103	REAL School RUSD	Transcripted Credit	2024FA	\$5,000.00	\$5,685.48			TCCF	
1104	Racine Lutheran High School	Transcripted Credit	2024SU	\$5,000.00	\$10,482.36			TCCF	
1105	Westosha Central High School	Transcripted Credit	2024FA	\$20,000.00	\$77,444.80			TCCF	
1106	Westosha Central High School	Transcripted Credit	2024FA	\$10,000.00				TCCF	Year Long
1107	Waterford Union High School	Transcripted Credit	2024FA	\$45,000.00	\$125,217.08			TCCF	
1108	Waterford Union High School	Transcripted Credit	2024FA	\$55,000.00				TCCF	Year Long
1109	Big Foot High School	Transcripted Credit	2024FA	\$15,000.00	\$41,530.72			TCCF	
1110	Big Foot High School	Transcripted Credit	2024FA	\$50,000.00				TCCF	Year Long
1111	Badger High School	Transcripted Credit	2024FA	\$75,000.00	\$126,102.88			TCCF	
1112	Badger High School	Transcripted Credit	2024FA	\$55,000.00				TCCF	Year Long
1113	Burlington High School	Transcripted Credit	2024FA	\$45,000.00	\$98,863.68			TCCF	
1114	Burlington High School	Transcripted Credit	2024FA	\$45,000.00				TCCF	Year Long
1115	East Troy High School	Transcripted Credit	2024FA	\$15,000.00	\$168,492.35			TCCF	
1116	East Troy High School	Transcripted Credit	2024FA	\$15,000.00				TCCF	Year Long

2024-2025 Contract Log Numbers Dual Credit CFS HS

1117	Lakeview Technology Academy	Transcripted Credit	2024FA	\$5,000.00	\$23,959.68	TCCF		
1118	Lakeview Technology Academy	Transcripted Credit	2024FA	\$5,000.00		TCCF		Year Long
1119	Elkhorn Area High School	Transcripted Credit	2024FA	\$165,000.00	\$197,043.68	TCCF		
1120	Elkhorn Area High School	Transcripted Credit	2024FA	\$12,000.00		TCCF		Year Long
1121	Bradford High School	Transcripted Credit	2024FA	\$30,000.00	\$27,453.80	TCCF		
1122	Bradford High School	Transcripted Credit	2024FA	\$15,000.00		TCCF		Year Long
1123	Indian Trail High School	Transcripted Credit	2024FA	\$20,000.00	\$28,801.56	TCCF		
1124	Indian Trail High School	Transcripted Credit	2024FA	\$15,000.00		TCCF		Year Long
1125	Reuther High School	Transcripted Credit	2024FA	\$2,000.00	\$1,996.64	TCCF		
1126	Tremper High School	Transcripted Credit	2024FA	\$45,000.00	\$55,317.04	TCCF		
1127	Tremper High School	Transcripted Credit	2024FA	\$50,000.00		TCCF		Year Long
1128	Oak Creek High School	Transcripted Credit	2024FA	\$45,000.00	\$48,591.20	TCCF		
1129	Horlick High School	Transcripted Credit	2024FA	\$50,000.00	\$50,564.88	TCCF		
1130	Horlick High School	Transcripted Credit	2024FA	\$25,000.00		TCCF		Year Long
1131	Whitewater High School	Transcripted Credit	2024FA	\$70,000.00	\$105,821.92	TCCF		
1132	Whitewater High School	Transcripted Credit	2024FA	\$30,000.00		TCCF		Year Long
1133	Wilmot High School	Transcripted Credit	2024FA	\$40,000.00	\$77,632.90	TCCF		
1134	Wilmot High School	Transcripted Credit	2024FA	\$12,000.00		TCCF		Year Long
1135	Delavan-Darien High School	Transcripted Credit	2024FA	\$80,000.00	\$87,722.44	TCCF		
1136	Delavan-Darien High School	Transcripted Credit	2024FA	\$90,000.00		TCCF		Year Long
1137	Delavan-Darien Tech School	Transcripted Credit	2024FA	\$15,000.00	\$17,146.16	TCCF		
1138	Delavan-Darien Tech School	Transcripted Credit	2024FA	\$10,000.00		TCCF		Year Long
1139	Verona High School	Transcripted Credit	2024FA	\$5,000.00	\$23,231.08	TCCF		
1140	Williams Bay High School	Transcripted Credit	2024FA	\$1,000.00	\$4,243.00	TCCF		
1141	Park High School RUSD	Transcripted Credit	2024FA	\$60,000.00	\$97,371.20	TCCF		
1142	Park High School RUSD	Transcripted Credit	2024FA	\$10,000.00		TCCF		Year Long
1143	REAL School RUSD	Transcripted Credit	2024FA	\$1,000.00		TCCF		Year Long
1144	Career and College Academy	Transcripted Credit	2024FA	\$5,000.00		TCCF		Year Long
1145	Tomah High School	Transcripted Credit	2024FA	\$1,000.00	\$10,382.68	TCCF		
1146	Burlington High School	543-102-3EGB	2025FA	\$450.00		HS	Nursing	
1147	Career and College Academy	900-003-1HCCA	2024SU	\$200.00	\$193.50	HS		Accident Insurance
1148	Franklin High School	900-003-1HFRH	2024SU	\$10.00	\$9.00	HS		Accident Insurance
1149	Greenfield High School	900-003-1HGRF	2024SU	\$10.00	\$18.00	HS		Accident Insurance
1150	KUSD	900-003-1HKUS	2024SU	\$100.00	\$90.00	HS		Accident Insurance
1151	Mukwonago High School	900-003-1HMUK	2024SU	\$200.00	\$180.00	HS		Accident Insurance
1152	RUSD	900-003-1HRUS	2024SU	\$150.00	\$162.00	HS		Accident Insurance
1153	REAL School RUSD	900-003-1HREA	2024SU	\$600.00	\$621.00	HS		Accident Insurance
1154	Union Grove High School	900-003-1HUGH	2024SU	\$100.00	\$85.50	HS		Accident Insurance
1155	Ktech High School	Transcripted Credit	2024FA	\$300.00	\$303.30	TCCF		
1156	Palmyra-Eagle High School	Transcripted Credit	2024FA	\$6,000.00	\$3,344.40	TCCF		

2024-2025 Contract Log Numbers Dual Credit CFS HS

1157	Nathan Hale High School	Transcripted Credit	2024FA	\$8,000.00	\$8,984.88		TCCF		
1158	Ktech High School	900-003-2HKTC	2024FA	\$1,800.00	\$1,800.00		HS		KTEC Vangaurd Mobile Unit
1159	Greendale High School	900-003-1HGRN	2024SU	\$30.00	\$31.50		HS		Accident Insurance
1160	St. Francis High School	900-003-1HSTF	2024SU	\$5.00	\$4.50		HS		Accident Insurance
1161	Whitnall High School	900-003-1HWHT	2024SU	\$20.00	\$22.50		HS		Accident Insurance
1162	Multi-Recipient	900-003-1HGWF	2024SU	\$2,000.00	\$2,000.00		HS		Out District Charge
1163	Waterford Union High School	442-323-3ZGA, 442-333-2ZGA, 442-334-3ZGA, 442-324-3ZGA	2025SP	\$30,000.00			HS		
1164	Lakeview Technology Academy	152-186-3LGA, 152-097-3LGA, 152-101-3LGA, 152-157-3LGA, 152-102-3LGA	2025SP	\$30,000.00			HS		
1165	Lakeview Technology Academy	44-331-3LGA, 444-331-3LGB, 612-102-3LGA, 612-102-3LGB, 628-109-3LGA, 628-109-3LGB, 620-108-3LGA	2025SP	\$30,000.00			HS		
1166	Lakeview Technology Academy	664-100-3LGA	2025SP	\$9,000.00			HS	Grant	
1167	Career and College Academy	834-110-3EGA, 834-110-3EGB,801-198-3EGA, 801-198-3EGB, 801-136-3EGA, 809-198-3EGA, 802-302-3EGA, 806-203-3EGA	2025SP	\$76,000.00			HS		
1168	Burlington High School	442-323-3ZGB, 442-334-3ZGB, 442-324-3ZGB	2025SP	\$22,000.00			HS	Welding Academy	
1169	Wilmot High School	543-300-3ZGB	2025SP	\$3,000.00			HS		
1170	Oak Creek High School	543-300-3ZGM, 543-300-3ZGP	2025SP	\$6,000.00			HS		
1171	Multi-Recipient	543-300-3ZGS, 543-300-3ZGT, 543-300-3ZGG, 543-300-3ZGQ	2025SP	\$6,000.00			HS		
1172	Muskego High School	543-300-3ZGA, 543-300-3ZGO	2025SP	\$6,000.00			HS		
1173	Whitewater High School	543-300-3ZGR	2025SP	\$3,000.00			HS		
1174	Burlington High School	543-300-3ZGH	2025SP	\$3,000.00			HS		
1175	East Troy High School	543-300-3ZGC	2025SP	\$3,000.00			HS		
1176	Multi-Recipient	543-300-3ZGU	2025SP	\$3,000.00			HS		
1177	Waterford Union High School	543-300-3ZGI	2025SP	\$3,000.00			HS		
1178	Christian Life High School	145-119-3ZGA	2025SP	\$3,000.00			HS		



2024-2025 Contract Log Numbers Dual Credit CFS HS

1179	St. Catherine's High School	543-300-2RG1	2024FA	\$3,000.00	\$3,519.40		HS		
		664-105-3CGC, 664-120-3CGC, 444-331-3CGA, 605-138-3CGA, 605-136-3CGA, 614-150-3CGA, 607-104-3CGA, 664-120-3CGB, 664-105-3CGB, 444-336-3CGA, 605-138-3CGB, 605-136-3CGB, 614-150-3CGB, 607-104-3CGB							
1180	REAL School RUSD		2025SP	\$80,000.00			HS		
1181	Multi-Recipient	533-126-2WCE	2024FA	\$6,000.00	\$7,023.24	Big Foot, Burlington, Whitewater	VAN		
1182	Academy of Excellence	900-003-2HAOE	2024FA	\$5.00	\$4.50		HS		
1183	Big Foot High School	900-003-2HBIG	2024FA	\$9.00	\$9.00		HS		
1184	Burlington High School	900-003-2HBUR	2024FA	\$135.00	\$135.00		HS		
1185	Career and College Academy	900-003-2HAHS	2024FA	\$280.00	\$288.00		HS		
1186	Case High School RUSD	900-003-2HCAS	2024FA	\$27.00	\$27.00		HS		
1187	Christian Life High School	900-003-2HCHL	2024FA	\$80.00	\$81.00		HS		
1188	Delavan-Darien High School	900-003-2HDEL	2024FA	\$5.00	\$4.50		HS		
1189	Elkhorn Area High School	900-003-2HELK	2024FA	\$145.00	\$144.00		HS		
1190	Elkhorn Options Virtual Charter School	900-003-2HEKO	2024FA	\$5.00	\$4.50		HS		
1191	Brookfield East High School	900-003-2HELB	2024FA	\$85.00	\$85.50		HS		
1192	Harborside Academy	900-003-2HHSA	2024FA	\$13.00	\$13.50		HS		
1193	Ktech High School	900-003-2HKTE	2024FA	\$205.00	\$207.00		HS		
1194	Lakeview Technology Academy	900-003-2HLVT	2024FA	\$360.00	\$360.00		HS		
1195	Muskego High School	900-003-2HMUK	2024FA	\$85.00	\$85.50		HS		
1196	Oak Creek High School	900-003-2HOCS	2024FA	\$90.00	\$90.00		HS		
1197	Racine Lutheran High School	900-003-2HRLT	2024FA	\$18.00	\$18.00		HS		
1198	REAL School RUSD	900-003-2HRAL	2024FA	\$475.00	\$477.00		HS		
1199	Reuther High School	900-003-2HRUT	2024FA	\$5.00	\$4.50		HS		
1200	South Milwaukee High School	900-003-2HSMK	2024FA	\$75.00	\$76.50		HS		
1201	St. Catherine's High School	900-003-2HSTC	2024FA	\$117.00	\$117.00		HS		
1202	Union Grove High School	900-003-2HUNO	2024FA	\$63.00	\$63.00		HS		
1203	Park High School RUSD	900-003-2HPAK	2024FA	\$9.00	\$9.00		HS		
1204	Waterford Union High School	900-003-2HWAR	2024FA	\$90.00	\$90.00		HS		
1205	Westosha Central High School	900-003-2HWST	2024FA	\$45.00	\$45.00		HS		
1206	Whitewater High School	900-003-2HWHT	2024FA	\$45.00	\$45.00		HS		
1207	Horlick High School	900-003-2HHOL	2024FA	\$22.00	\$22.50		HS		
1208	Wilmot High School	900-003-2HWLM	2024FA	\$54.00	\$54.00		HS		
1209	Union Grove High School	Transcripted Credit	2025SP	\$170,000.00			TCCF		
1210	Badger High School	Transcripted Credit	2025SP	\$90,000.00			TCCF		
1211	Catholic Central High School	Transcripted Credit	2025SP	\$10,000.00			TCCF		
1212	East Troy High School	900-003-2HEAS	2024FA	\$31.00	\$31.50		HS		
1213	Multi-Recipient	809-172-2WGB	2024FA	\$500.00	\$499.16		HS		
1214	Burlington High School	Transcripted Credit	2025SP	\$80,000.00			TCCF		

2024-2025 Contract Log Numbers Dual Credit CFS HS

1215	Christian Life High School	Transcripted Credit	2025SP	\$7,000.00			TCCF		
1216	East Troy High School	Transcripted Credit	2025SP	\$75,000.00			TCCF		
1217	Ktech High School	Transcripted Credit	2025SP	\$5,000.00			TCCF		
1218	Bradford High School	Transcripted Credit	2025SP	\$15,000.00			TCCF		
1219	Indian Trail High School	Transcripted Credit	2025SP	\$15,000.00			TCCF		
1220	Reuther High School	Transcripted Credit	2025SP	\$10,000.00			TCCF		
1221	Oak Creek High School	Transcripted Credit	2025SP	\$45,000.00			TCCF		
1222	Racine Lutheran High School	Transcripted Credit	2025SP	\$9,000.00			TCCF		
1223	Lakeview Technology Academy	Transcripted Credit	2025SP	\$25,000.00			TCCF		
1224	St. Catherine's High School	Transcripted Credit	2025SP	\$25,000.00			TCCF		
1225	Multi-Recipient	501-101-2WCC	2024FA	\$13,000.00	\$12,978.16	Big Foot, Burlington	VAN		
1226	Wilmot High School	Transcripted Credit	2025SP	\$100,000.00			TCCF		
1227	Case High School RUSD	Transcripted Credit	2025SP	\$120,000.00			TCCF		
1228	Horlick High School	Transcripted Credit	2025SP	\$50,000.00			TCCF		
1229	Park High School RUSD	Transcripted Credit	2025SP	\$85,000.00			TCCF		
1230	Tomah High School	Transcripted Credit	2025SP	\$5,000.00			TCCF		
1231	Verona High School	Transcripted Credit	2025SP	\$6,000.00			TCCF		
1232	Delavan-Darien High School	Transcripted Credit	2025SP	\$80,000.00			TCCF		
1233	Delavan-Darien Tech School	Transcripted Credit	2025SP	\$8,000.00			TCCF		
1234	Waterford Union High School	Transcripted Credit	2025SP	\$50,000.00			TCCF		
1235	Westosha Central High School	Transcripted Credit	2025SP	\$90,000.00			TCCF		
1236	Whitewater High School	Transcripted Credit	2025SP	\$90,000.00			TCCF		
1237	Williams Bay High School	Transcripted Credit	2025SP	\$10,000.00			TCCF		
1238	Tremper High School	Transcripted Credit	2025SP	\$50,000.00			TCCF		
1239	Elkhorn Area High School	Transcripted Credit	2025SP	\$100,000.00			TCCF		
	Contract Revenue-HS & VAN			\$1,015,753.00	\$856,157.76				
	Contract Revenue-TCCF			\$3,122,300.00	\$1,950,736.47				
	<b>Total Contracts</b>		<b>234</b>	<b>\$4,138,053.00</b>	<b>\$2,806,894.23</b>				

# GATEWAY TECHNICAL COLLEGE DISTRICT BOARD

Roll Call \_\_\_\_\_  
Action   X    
Information \_\_\_\_\_  
Discussion \_\_\_\_\_

## ADVISORY COMMITTEE ACTIVITY REPORT

Summary of Item: Approval of:  
➤ New Members as of February 1, 2025

Staff Liaison: Matt Janisin

**GATEWAY TECHNICAL COLLEGE  
ADVISORY COMMITTEES -- NEW MEMBERS  
As of February 1, 2025**

PROGRAM Name	Job Title	Employer	County Represented
<b>Graphic Design</b>			
Michelle Struck	Owner	StrucknDesign	Racine
<b>Human Resources</b>			
Jen Dzymanski	Senior HR Manager	INNIO Waukesha Gas Engines	Out of District

## POLICY GOVERNANCE MONITORING REPORTS

### A. Ends Policy Monitoring

College Ends Policy - The tri-county community benefits from affordable higher education that allows residents to develop knowledge and skills for family-supporting careers that contribute to the growth and sustainability of the local economy at a cost commensurate with the value of services provided.

**#1 Students demonstrate the knowledge and skills and self-confidence required for employability, career advancement, a global perspective, and lifelong learning.** – Oliver Debe

### B. Executive Limitations

- 1) 3.7 Communication and Counsel to the Board – Jacqueline Morris

# GATEWAY TECHNICAL COLLEGE DISTRICT BOARD

Roll Call	_____
Action	<u>  X  </u>
Information	_____
Discussion	_____

## POLICY GOVERNANCE MONITORING REPORTS Ends Statement Monitoring

College Ends Policy - The tri-county community benefits from affordable higher education that allows residents to develop knowledge and skills for family-supporting careers that contribute to the growth and sustainability of the local economy at a cost commensurate with the value of services provided.

- 1) Students demonstrate the knowledge and skills and self-confidence required for employability, career advancement, a global perspective, and lifelong learning.**

**Staff Liaison:** Oliver Debe

# GATEWAY TECHNICAL COLLEGE DISTRICT BOARD

Roll Call \_\_\_\_\_  
Action   X    
Information \_\_\_\_\_  
Discussion \_\_\_\_\_

## POLICY GOVERNANCE MONITORING REPORT EXECUTIVE LIMITATIONS

### 3.7 –Communication and Counsel to the Board

The President shall not cause or allow the Board to be uninformed or inadequately supported in its work.

Without limiting the scope of the foregoing statement, the President shall not:

1. Neglect to submit monitoring data required by the Board (see Policy 2.4, Monitoring College Effectiveness) in a timely, accurate, and understandable fashion, and directly addressing provisions of the Board policies being monitored.
2. Allow the Board to be unaware of relevant trends, anticipated adverse media coverage, actual or anticipated legal actions, or material external and internal changes, particularly changes in the assumptions upon which any Board policy has previously been established.
3. Fail to advise the Board if, in the President's opinion, the Board is not in compliance with its own policies on Governance Process and Board/Staff Relationship, particularly in the case of Board behavior which is detrimental to the working relationship between the Board and the President.
4. Fail to marshal for the Board as many internal and external points of view, issues, and options as need to fully inform the Board's work.
5. Present information which is untimely, inaccurate, incomplete, overly complex or lengthy, or misleading, or which is in a format unusable by the Board.
6. Fail to provide a mechanism for official Board, officer, or ad hoc committee communications.
7. Fail to deal with the Board as a whole except when (a) fulfilling individual requests for information or (b) responding to officers or committees duly charged by the Board.
8. Fail to report in a timely manner any actual or anticipated non-compliance with any Board policy.
9. Fail to supply for the consent agenda all items delegated to the President yet required by law or contract to be Board-approved, along with evidence of the college's due diligence on behalf of the Board.

Staff Liaison: Jacqueline Morris

## NEXT MEETING DATE AND ADJOURN

- A. Regular Meeting – Thursday, March 20, 2025, **3 pm**, Virtual and In-Person, Horizon Center, Kenosha, WI.
- B. Adjourn – Immediately following the Regular Meeting, the Gateway Technical College District Board will meet for a **semi-annual retreat**, with no public virtual or in-person option.

## ROLL CALL

Ram Bhatia	_____
Benjamin DeSmidt	_____
William Duncan	_____
Preston Gardner	_____
Zaida Lange-Irisson	_____
Rebecca Matoska-Mentink	_____
Nicole Oberlin	_____
Scott Pierce	_____
Jason Tadlock	_____